



RWA12

RWA12H

Natural smoke & heat exhaust ventilator with pneumatic actuation

for installation in false ceilings of **cold stores and freezer rooms** – with
CE marking in accordance with EN 12101-2:2003

**SMOKE VENTILATION SYSTEMS
FOR COLD STORES AND FREEZER ROOMS**



Please make sure that you are informed about the current status of this document. This is a technical information sheet. The publication of an updated version supersedes

and renders obsolete any previous versions. Thank you!

4TH EDITION – MARCH 2021



Outstanding quality

The *cool it* ceiling hatches are manufactured from high-quality materials using state-of-the-art production methods.

Our smoke extraction hatches for installation in the false ceiling and façade

- 1** Pneumatically or electrically operated ceiling hatch for installation in false ceilings (RWA12/RWA12H)
- 2** New since 12/2020: BL12RWA wall hatch, tested in accordance with DIN EN 12101-2
- 3** New since 12/2020: BL12ZL supply air hatch for wall installation

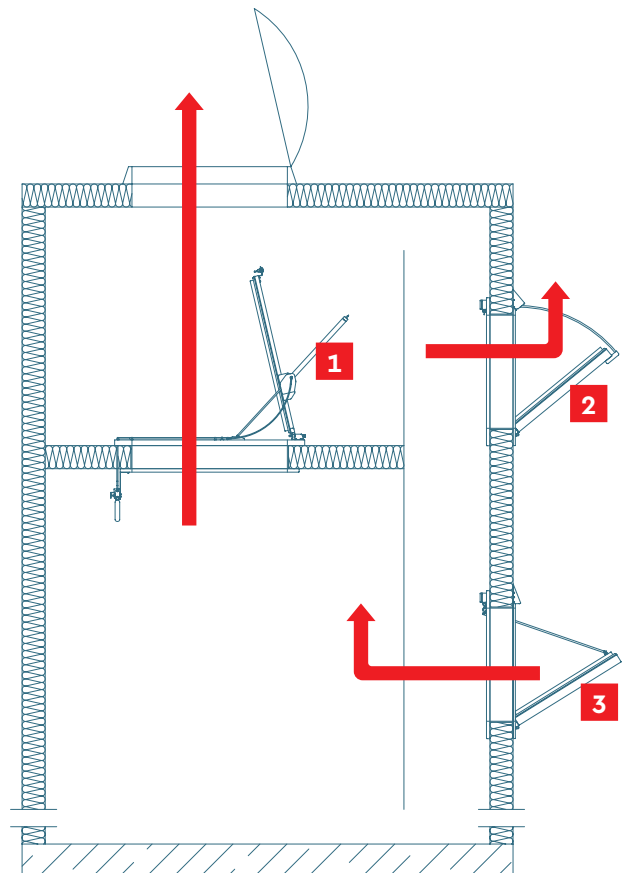

Whenever a reliable thermal room sealing point is required, *cool it* has proven itself to be a strong partner for over 35 years. And *cool it* also excels with innovative solutions in the field of smoke and heat ventilation systems. More than ten years of experience underpin every single *cool it* ventilation hatch. The results of this continuous further development are top-quality, ventilation hatches for cold stores and freezer rooms that have proven themselves in practical use.

For practically any application or requirements – with the optional extensions to the standard *cool it* smoke and ventilation hatches, anything is possible.

Hygiene/occupational health and safety: In freezer rooms, it is important that no ice can form in the area around the ceiling hatches. That is why the *cool it* hatch has been engineered to open "upwards". On hatches that open "downwards", water condensation necessarily collects on the hatch sheet and then penetrates through the seal into the interior of the room. This can cause hygiene-related problems in cold stores or cause hazardous icicles to form in freezer rooms.

Corrosion-resistant materials: All add-on parts of the hatch consist of corrosion-resistant materials – stainless steel is used for the brackets and aluminium for the locks.

Optimum operating reliability: VdS-tested mounting parts and the frame heater (RWA12H) that is fitted as standard effectively prevent the seal from freezing tight to the frame. The 4-point locking mechanism guarantees an optimised hermetic seal.

Energy efficiency: The use of special connecting elements prevents the formation of thermal bridges. The insulation values of the 12 cm-thick hatch sheet ensure minimum energy loss.

Safe acceptance: The *cool it* SHEV hatches create safety for everyone involved in the construction project and thus enable your building to be commissioned on schedule.

The *cool it* smoke and ventilation hatches with pneumatic actuation – thoroughly tested by leading experts.



CE marking to
DIN EN 12101-2

Design of the pneumatic ceiling hatch

Output from the frame heater

Moisture-proof supply line from the flat frame, shown with on-site junction box



Heater monitoring

Pre-mounted on the frame with potential-free feedback contacts for on-site evaluation



Locking unit

Opening system lock with fixed locking bolt in stainless steel

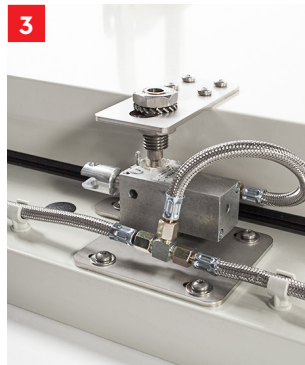

Laying the flexible CO₂ hoses

Airtight bushings through the frame prevent the formation of condensation or ice in the interior



Thermal trigger unit

TAG with 120 gram CO₂ bottle and fire detection element for automatic individual thermal release in case of fire

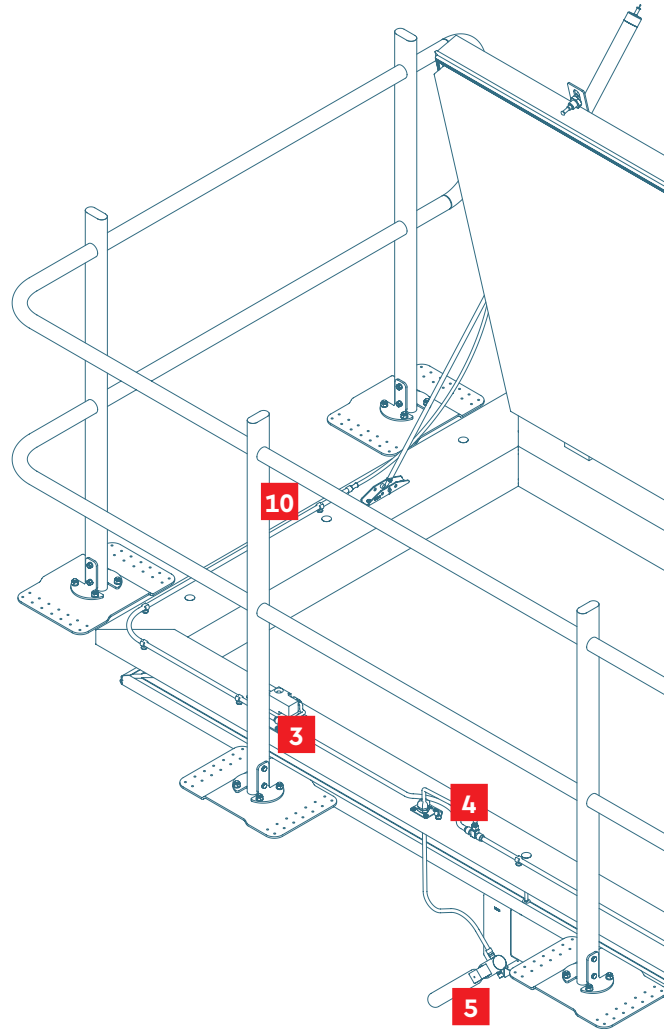
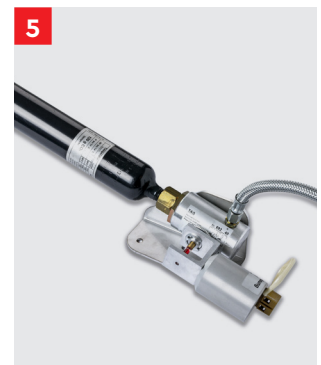

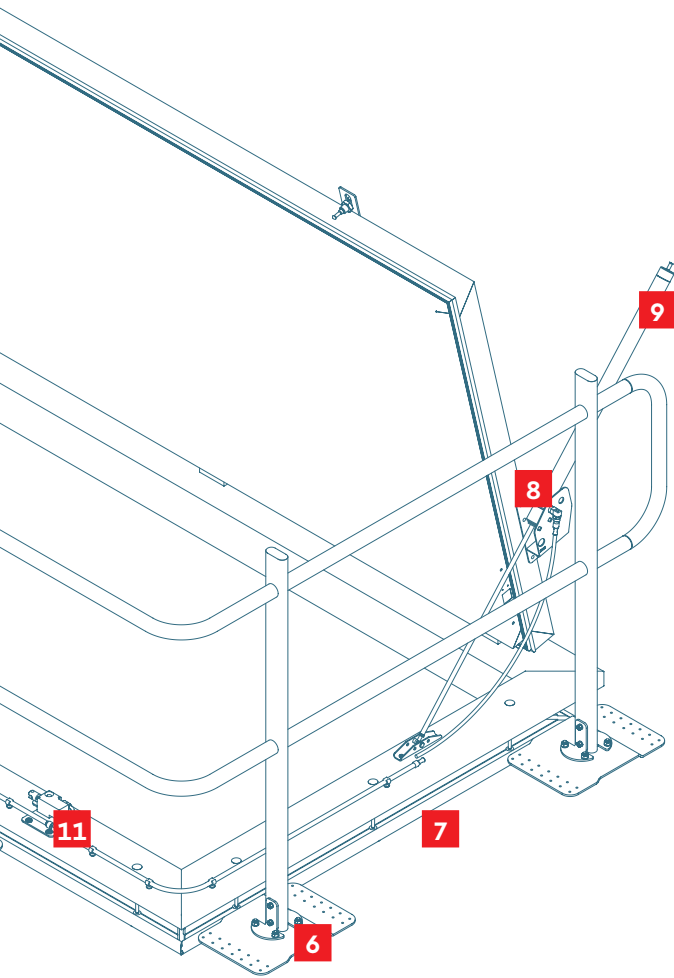

Feedback contact
 "Hatch open"/"Hatch closed"
 for control or polling of on-site
 systems or displays



Pneumatic actuating cylinders
 for opening angles from 41° to 77°
 with cylinder strokes from 350 mm
 to 600 mm



Brackets for actuating cylinders
 Stainless steel brackets on blade
 and frame made of 1.4301
 stainless steel to hold the
 actuating cylinders



Fall-arrester
 6 mm base plates on the
 fall-arrester with approval for
 riveting to panel ceilings



Thermotec flat frame
 for RWA12H with heating cable
 and aluminium cover profile



The ceiling hatches in detail

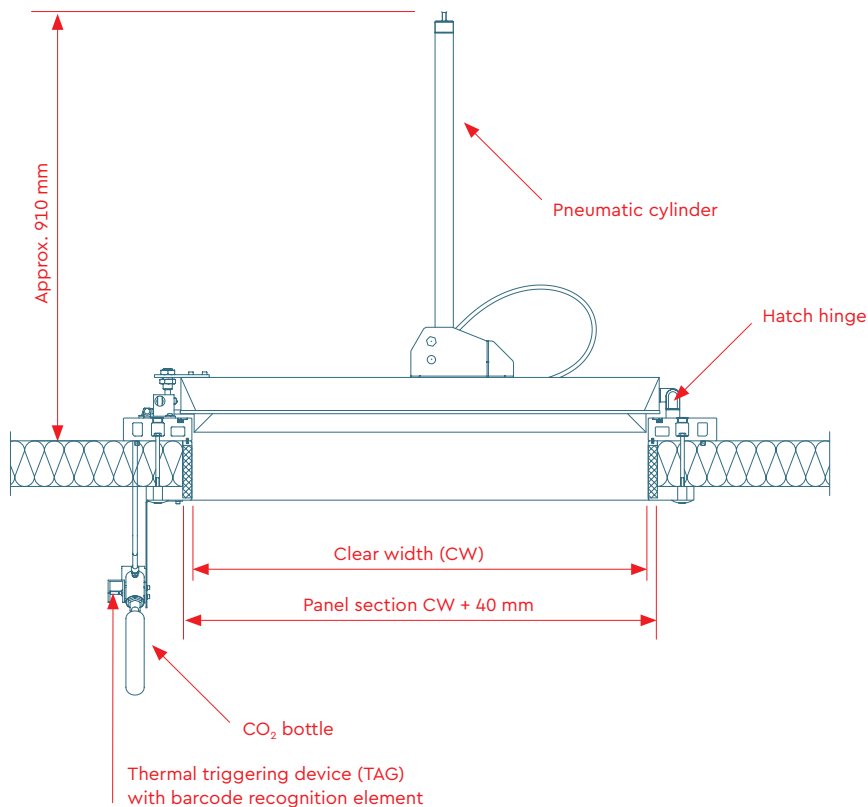

Closed state

When closed, the ceiling hatch meets all thermal partitioning requirements in cold stores and freezer rooms: high insulation values, good sealing properties, no thermal bridges. The clamping frame system is ideal for installation in sandwich panels.

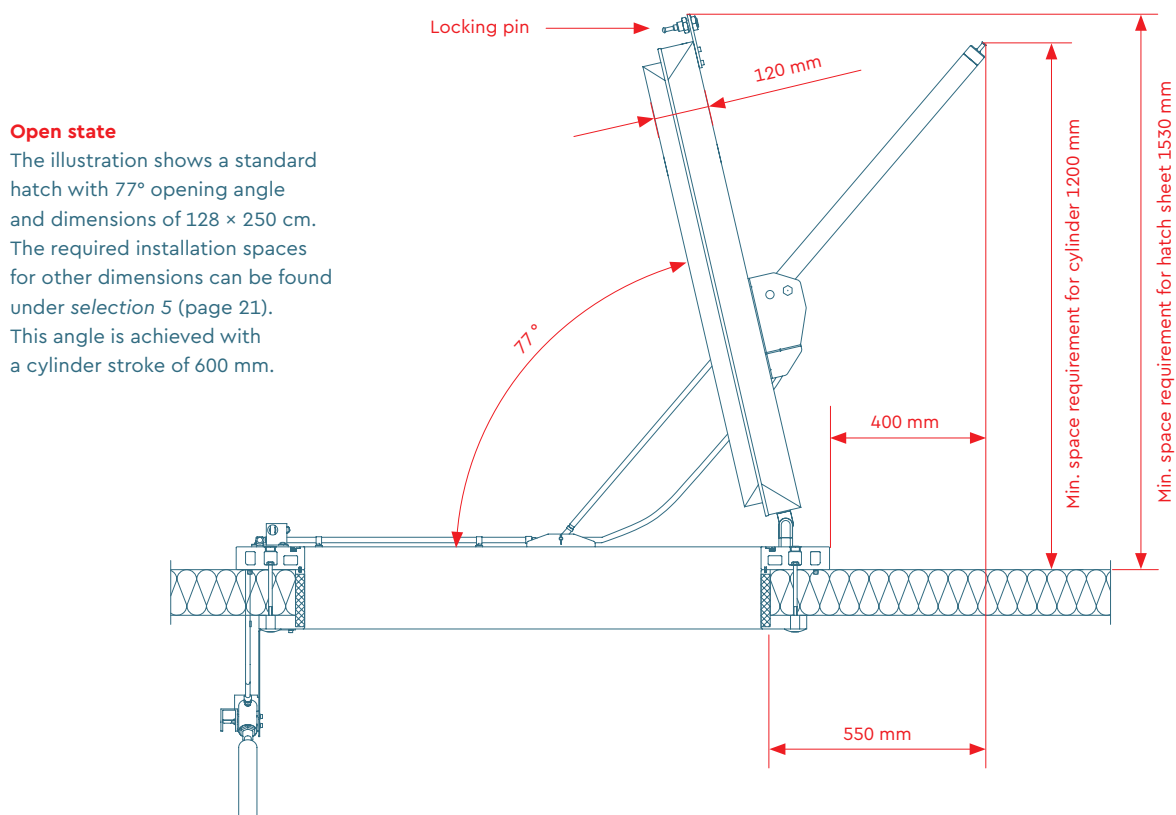

Open state

The illustration shows a standard hatch with 77° opening angle and dimensions of 128 × 250 cm. The required installation spaces for other dimensions can be found under *selection 5* (page 21). This angle is achieved with a cylinder stroke of 600 mm.

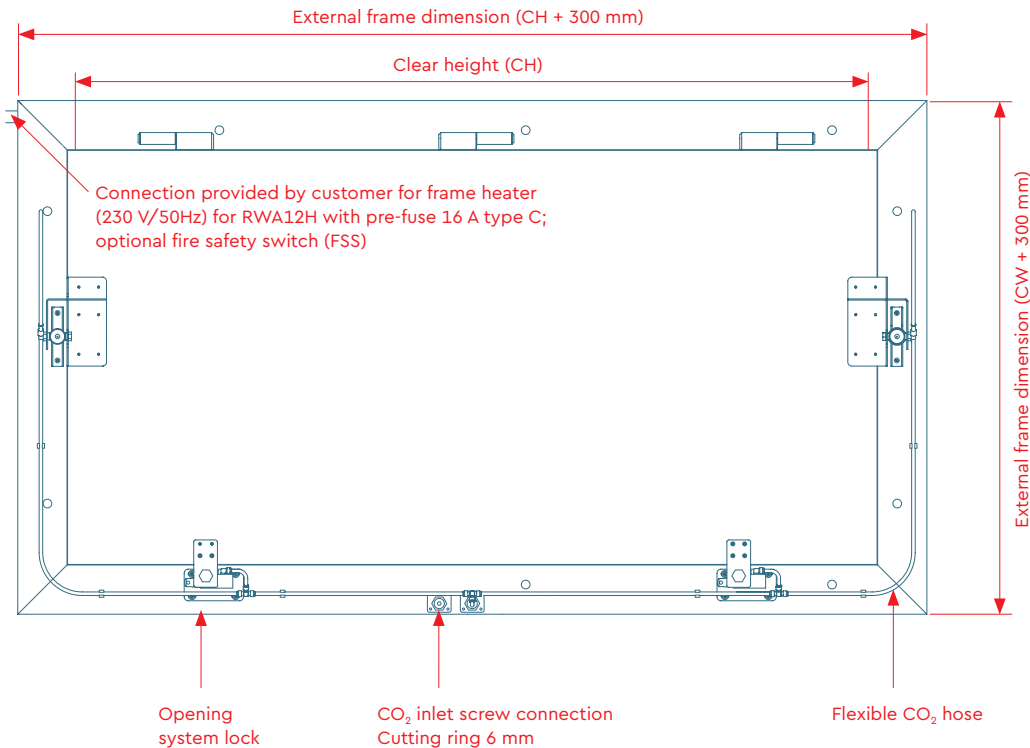

Top view

We supply the standard hatch in the maximum size of 1280 mm × 2500 mm. The minimum dimensions are 800 mm × 800 mm.

Maximum leak tightness

Due to the four existing locking points between the hatch sheet and the frame (2 × opening system lock + 2 × pneumatic cylinder), the hatch system is always optimally locked, regardless of seasonal extreme temperature differences in the false ceiling.

Detailed view of frame

The RWA12H, the hatch for freezer rooms, is also equipped with a frame heater and interior surface insulation. Thanks to the thermal insulation gap, the frame is designed to have no thermal bridges.

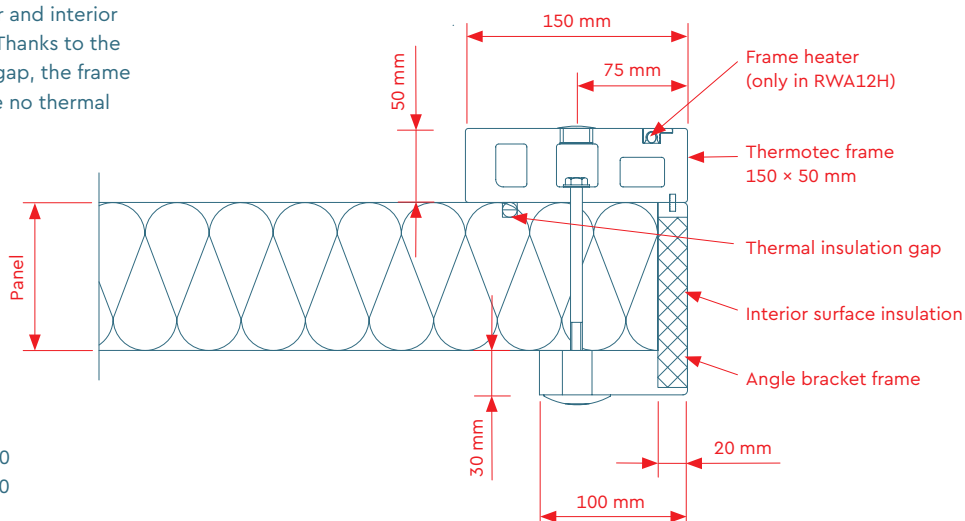

Panel cut-out

Clear height CH +40
Clear width CW +40

The declared performance of the RWA12 corresponds to the DIN EN 12101-2:2003 product standard

UNIQUE IDENTIFICATION CODE FOR THE PRODUCT TYPE

Smoke extraction ceiling hatch type RWA12
 Opening angle: 77°, 63°, 48°, 41°
 Cylinder stroke: 600 mm, 500 mm, 400 mm, 350 mm
 Actuator type: pneumatic

A sample declaration of performance can be found on this page.

The product-specific declarations of performance in the respective national languages can be found at www.coolit.de/downloads.



PURPOSE

Fire protection
 Natural smoke and heat ventilator (NSHV)
 for installation in false ceilings, installation inclination 0° to horizontal

SYSTEM FOR THE EVALUATION OF PERFORMANCE STABILITY

1

HARMONISED STANDARD

EN 12101-2: 2003

NOTIFIED BODY

MPA NRW – NB No. 0432

KEY FEATURES	DESCRIPTION OF THE FEATURE	SECTIONS WITH THE REQUIREMENTS	MANDATED CLASS	HARMONISED TECHNOLOGICAL SPECIFICATION
NOMINAL TRIGGER CONDITIONS/SENSITIVITY	Thermal trigger element	4.1	passed	EN 12101-2: 2003
	Pneumatic opening mechanism	4.2	passed	EN 12101-2: 2003
DELAYED RESPONSE		7.1.2	passed	EN 12101-2: 2003
FUNCTIONAL SAFETY	without external load	7.1	Re 100 (type A)	EN 12101-2: 2003
	Comfort/ventilation position	7.1.3	npd	EN 12101-2: 2003
	Wind load	7.4	WL 0	EN 12101-2: 2003
EFFECTIVENESS OF SMOKE AND HEAT DISSIPATION/AERODYNAMICALLY EFFECTIVE OPENING AREA		6	A ₃ (see selection 5)	EN 12101-2: 2003
PERFORMANCE UNDER FIRE CONDITIONS, FIRE RESISTANCE – MECHANICAL INTEGRITY, HEAT RESISTANCE		7.5	B ₃₀₀ 30	EN 12101-2: 2003
OPENING UNDER ENVIRONMENTAL CONDITIONS	Snow load	7.2	SL 0	EN 12101-2: 2003
	Snow load at low ambient temperatures	7.3	T (-20) with SL 0	EN 12101-2: 2003
FIRE PERFORMANCE OF CONSTRUCTION MATERIALS		7.5.2.1	E	EN 13501-2: 2010

Technical information

RWA12 HATCH FOR COLD STORES		RWA12H HATCH FOR FREEZER ROOMS	
DIMENSIONS			
Min. size	800 mm × 800 mm		
Max. size	1280 mm × 2500 mm		
Weight 1280 mm × 2500 mm	approx. 130 kg		
AMBIENT TEMPERATURE			
Room	≥ 4 °C to 60 °C *	< 4 °C to -28 °C	down to -50 °C **
False ceiling	min. -20 °C		min. -20 °C
INSULATION PROPERTIES			
Heat transfer coefficient	$U_w = 0,595 \frac{W}{m^2 \times K}$ (U value to DIN EN ISO 10077-1)		
MATERIAL			
Top side of hatch sheet	Stainless steel or steel aluminium sheet 0.63 mm – 0.8 mm; galvanised and plastic-coated		
Core insulation of ceiling hatch sheet	Polyurethane B2 as per DIN 4102-1, no thermal bridges with 120 mm thickness of insulation		
Frame	PVC, Thermotec frame: 150 mm × 50 mm		
MECHANICAL CONSTRUCTION			
Pneumatic cylinder	Jofo, PCV 32, Type 00 and 04		
Locking units	Jofo, TS 6000 P		
AERODYNAMIC OPENING SURFACE			
see selection 5			
FRAME HEATER			
Performance	self-regulating, 27 W/m at 10 °C (max. 50 W)		
Electrical connections (provided by the customer)	Power supply 230 V/50 Hz , pre-fuse 16 A type C , residual current circuit breaker 30 mA Total capacity = (2 × CL [m] + 2 × CW [m]) × 50 W The capacity of all the heaters connected to a fuse must be less than 1000 W.		
SHEV SYSTEM (PROVIDED IN BUILDING)			
CO ₂ volume	1.35 litres for the complete system as of the screw connection		
CO ₂ quantity	100 grams at -5 °C		
CO ₂ pressure	Initial pressure: min. 25 bar ; final pressure: max. 60 bar		

* higher temperatures on request ** on request, special equipment may reduce the temperature distribution.

Thermal trigger unit as standard equipment in accordance with DIN EN 12101-2:2003, section 4.1

Normative basis: DIN EN 12101-2:2003- (p. 14 – 4.1.1.1) requires an automatic individual release of each hatch in addition to a manual release. For this reason, the *cool it* SHEV hatch has the TAG fitted as standard. When testing the system, the TAG was also tested using the mounting method on the angle bracket frame, including the response time.

Delivery of the hatch without TAG: It is also possible for the hatch to be supplied without TAG, in which case an automatic trigger must be provided by the customer in accordance with the standard. Otherwise, it no longer conforms to the standard and loses its approval.

For alternative variants for creating a single trigger, see *selection 9*. If anything is unclear, please contact the planner responsible for the fire protection concept or the appraiser.

Functionality: The thermal single release is achieved, as required in section 4.1 of the standard, by means of the TAG 690-WV-41 system approved by the Vds. It is a decentralised CO₂ trigger unit mounted on the clamping frame. Compliance with the geometric arrangement of the TAG in the room prescribed by the standard is ensured by adhering to the specified mounting position.

If a fire occurs, the fire detection element (glass piston) integrated in the TAG is destroyed by the heat and the CO₂ stored in the energy source (120 g CO₂ bottle) is released. The pressure is transmitted to the opening cylinders and opening locks via the pre-assembled flexible hoses. After pneumatic unlocking of the hatch, it opens to the max. opening angle in approx. 5 sec. When the maximum opening angle is reached, the hatch locks mechanically so that it remains safely open even if the CO₂ system pressure drops. See *selection 9, variant 1*

Redundant power supply: The TAG used has a shuttle valve as standard. A central CO₂ trigger can be connected via a second hose connection. A complete trigger group can thus be opened by means of a CO₂ alarm box. With this type of triggering, the fire detection element installed in the TAG and the CO₂ cylinder are not "consumed" and therefore do not need to be replaced. See *selection 9, variant 3*

Electrical remote initiation: Optionally, it is possible to equip the TAG with an electric solenoid (24 V). This mechanically destroys the fire detection element and thus releases the stored energy. See *selection 9, variant 2*

Notes on planning for food production/wet areas: Due to the method of installation, fragments of glass necessarily fall into the unit after triggering. Therefore – and due to the IP00 electrical protection class – the system is not suitable for areas where open food is handled and/or wet cleaning is carried out. In addition, the standard TAG and the solenoid is made of aluminium and is therefore attacked and rapidly destroyed by the cleaning agents used in the food industry.

If the use of this system is required by the customer, the TAG can alternatively be made of stainless steel; there is no alternative option for the solenoid.

As the CO₂ cylinder is not corrosion resistant, the maintenance interval may need to be adjusted according to the individual site conditions.



Trigger unit

Left: fully assembled trigger unit for mounting on the angle bracket frame Right: the 120 g CO₂ bottle as the energy source



Variants and technical data

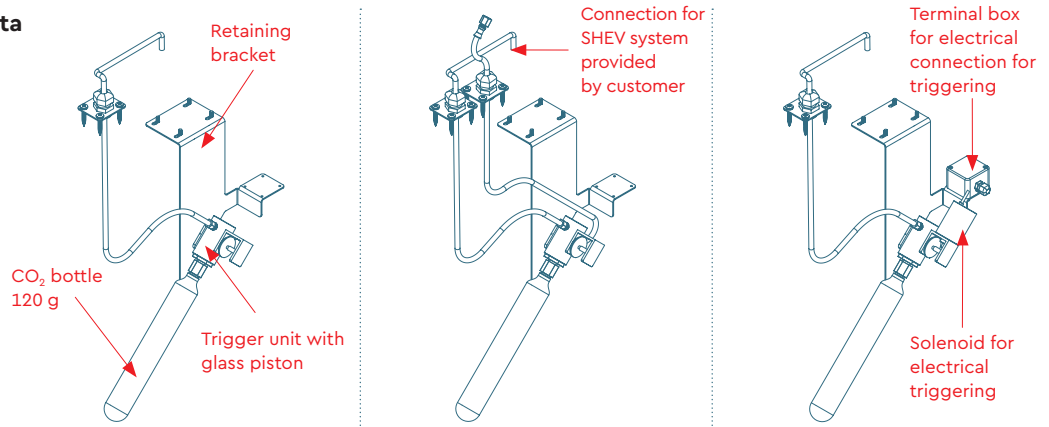

TRIGGERING METHOD			
Thermal triggering with fire detection element	•	•	•
Connection to the CO ₂ system provided by the customer		•	•
Electrical triggering via signal provided by the customer			•
THERMAL TRIGGERING			
Fire detection element	Standard: Glass piston 68°C (optional: 93°C, 141°C, 182°C)		
Energy source	CO ₂ bottle 120 g		
Material	Standard: Aluminium (optionally available in stainless steel)		
Ambient temp. for use	-25°C to +80°C		-20°C to +80°C
ELECTRICAL TRIGGERING			
Triggering voltage			24 V DC
Performance			Idle current 1.6 W, pulsed current 3.5 W
Connecting cable			Two-core, calculation based on line length and number of units
Percentage duty cycle			100% PDC
Temperature range			-20°C to +80°C
Safety class			IP00

Position

The trigger unit is positioned in the centre of the clear area below the frame. It can be connected to the piping through a hose duct.

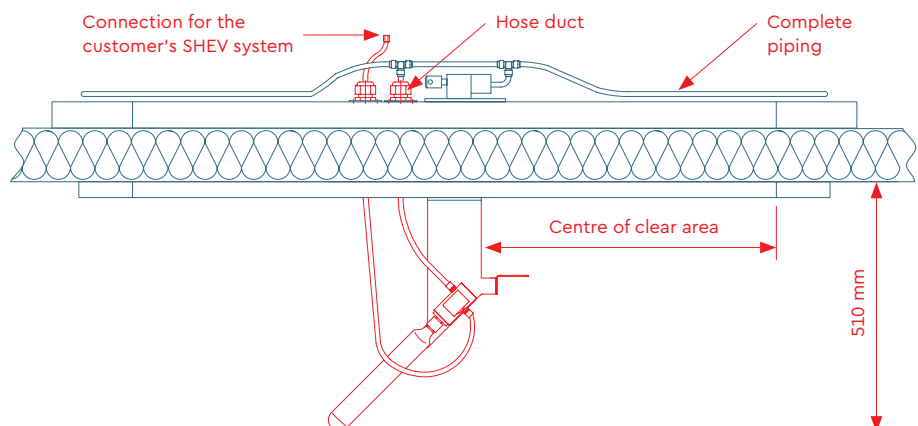

Configure the right hatch for your requirements

Use the planning aid shown opposite to quickly get an overview of the optional extras that are available for your *cool it* smoke extraction hatch. This way, you can quickly find the right model for your requirements, allowing you to select the most effective and economical system for each building project.

Do you need support?

Do you need assistance with your project planning? *cool it* supports your entire project in all phases. We would be happy to provide you with all the information you need. Talk to us!

Phone **+49 (0) 54 22 6 09-0**

SELECTION

1

Climatic conditions

Hatch for cold stores or freezer rooms

COLD STORES > +4°C WITHOUT FRAME HEATER RWA12

FREEZER ROOM +4°C TO -28°C WITH FRAME HEATER RWA12H

SELECTION

2

Ceiling construction

Installation with or without angle bracket frame

SOLID CEILING/CONCRETE CEILING

PANEL CEILING WITH PANEL THICKNESS

SELECTION

3

Material and surface

Hatch sheet outer shell/ inner shell

EXTERIOR SHEET STAINLESS STEEL

OUTER SHEET SHEET METAL IN RAL COLOUR

INNER SHEET STAINLESS STEEL

INNER SHEET SHEET METAL IN RAL COLOUR

SELECTION

4

Temperature and mains voltage monitoring for the frame heater

WITH TEMPERATURE AND MAINS VOLTAGE MONITORING

WITHOUT TEMPERATURE AND MAINS VOLTAGE MONITORING

SELECTION

5

Hatch dimensions corresponding to the aerodynamically effective opening area

OPENING ANGLE [°] 77°, 63°, 48°, 41°

CLEAR WIDTH CW [MM] 800-1250 MM

CLEAR HEIGHT CH [MM] 800-2500 MM

SELECTION

6

Door contact switch for response message ("hatch open" or "hatch closed")

HATCH OPEN

HATCH CLOSED

HATCH OPEN AND HATCH CLOSED

WITHOUT DOOR CONTACT SWITCH

SELECTION

7

Fall-arrester

Collective protection system

WITH FALL-ARRESTER COLLECTIVE PROTECTIVE GRATING

WITHOUT FALL-ARRESTER COLLECTIVE PROTECTIVE GRATING

SELECTION

8

Fire safety switch (FSS)

in accordance with DIN VDE 0100-420 (only for RWA12H)

FSS + RESIDUAL CURRENT DEVICE/ CIRCUIT BREAKER

FSS + RESIDUAL CURRENT DEVICE/ CIRCUIT BREAKER

WITHOUT FSS

SELECTION

9

Design variants/ signal transmission/ interconnections on site

COLD STORE

FREEZER ROOM

HYGIENE

Climatic conditions

Hatch for cold stores or freezer rooms

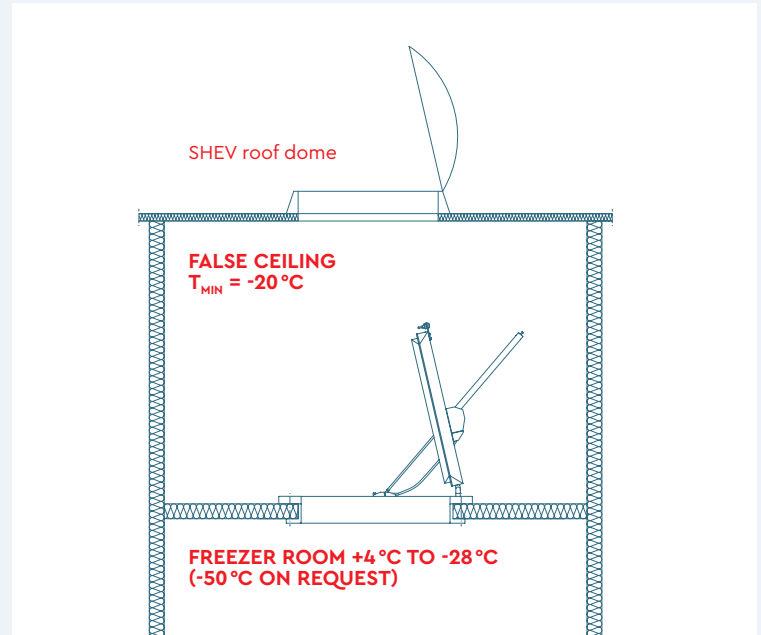
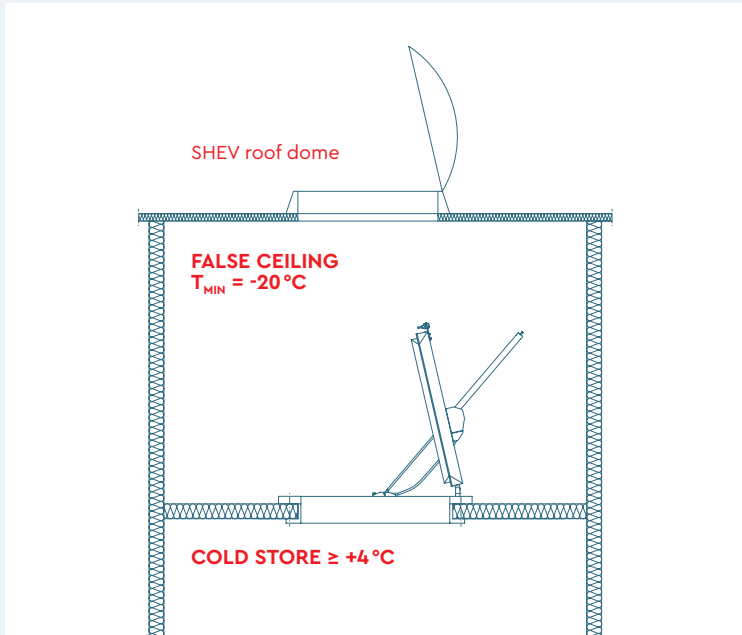

COLD STORE $\geq +4^{\circ}\text{C}$
WITHOUT FRAME HEATER MODEL RWA12

FREEZER ROOM $+4^{\circ}\text{C TO } -28^{\circ}\text{C}$
WITH FRAME HEATER MODEL RWA12H

Two different variants of the *cool it* hatches are available, which are derived from the climatic conditions on site. The limit temperature on the inside is 4°C . The basic geometric design of the hatches is identical.

Below the limit temperature, however, the hatch is equipped with a frame heater as standard, which keeps the area of the seal free of ice and ensures safe opening at all times.

Hygiene: In processing areas of the food industry where open products are handled, droplet contamination through condensation water is an existential problem. Heating of the hatch in the weakly insulated sealing area effectively prevents the formation of condensation water.

Technical data for the frame heater

- Self-regulating heating cable, 27 W/m at 10°C (max. 50 W).
- Power supply 230 V/50 Hz
- Pre-fuse 16 A, type C
- Residual current device/circuit breaker 30 mA

The capacity of all the heaters connected to a fuse must be less than 1000 W. The total output of the frame heater can be calculated using the following formula:

$$\text{Power consumption [W]} = (2 \times \text{CH [m]} + 2 \times \text{CW [m]}) \times 50\text{W} \leq 1000\text{ W}$$

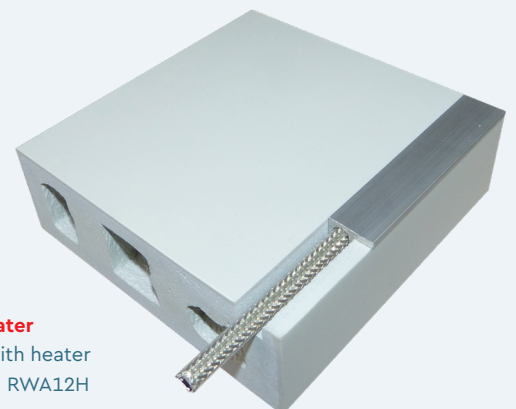

View of the frame heater
in Thermotec frame with heater cover profile in model RWA12H for freezer rooms

Ceiling construction

Installation with or without angle bracket frame

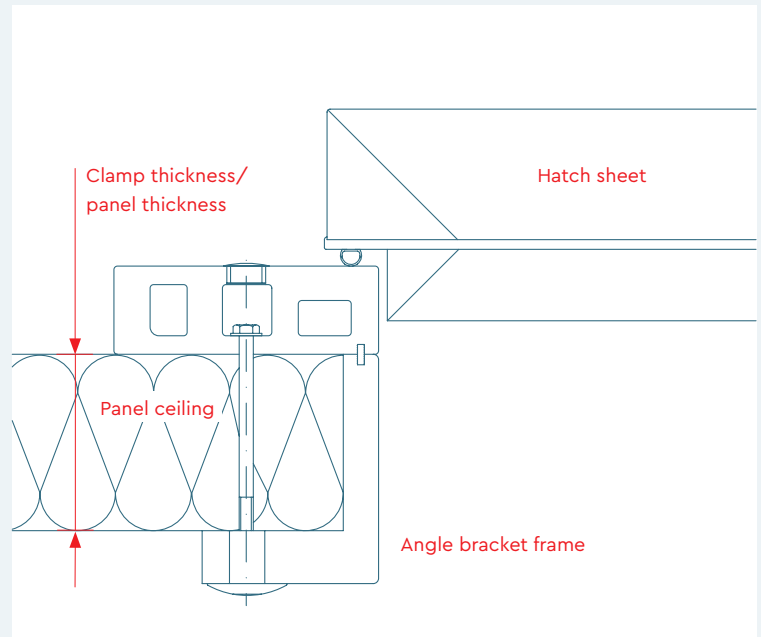
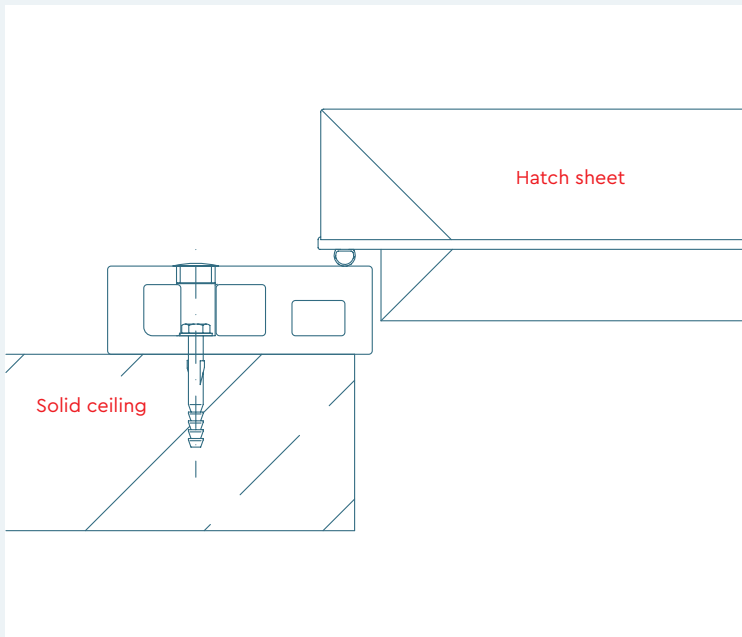

SOLID CEILING/CONCRETE CEILING



PANEL CEILING



PANEL THICKNESS [MM]



Two mounting variants are available. The standard variant is **panel mounting, whereby the cool it SHEV hatch is clamped and bolted to the panel using an angle bracket frame**. With this type of installation, the exact thickness of the panel must also be known in order to securely fix the hatch. The clamp thickness required for ordering corresponds to the panel thickness.

Alternatively, **installation on a solid ceiling** is possible. In this case, the hatch is fixed using dowels and suitable screws.

Fixing materials: The required fixings for the chosen installation type are included with the cool it SHEV hatch on delivery.



Angle bracket frame

Mounting in a panel ceiling using an angle bracket frame.

Material and surface

Hatch sheet outer shell/inner shell

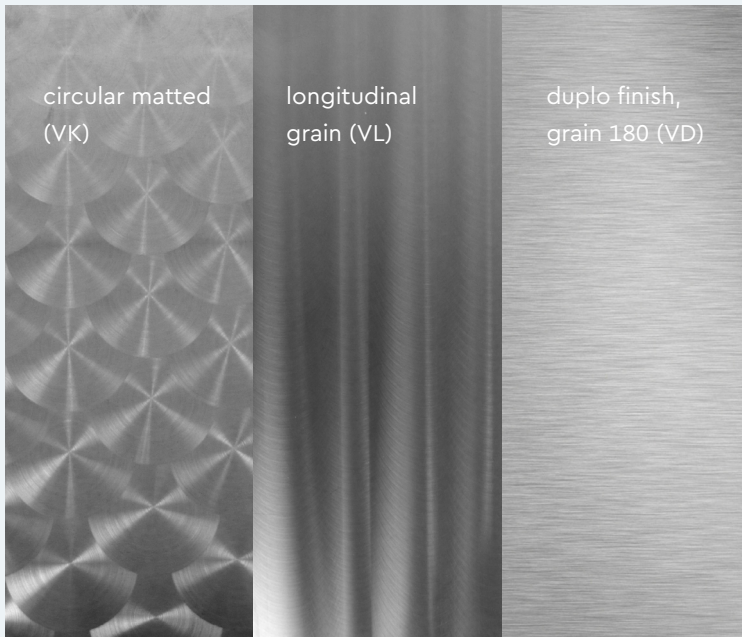

RAL 1021 (Rape yellow)	RAL 3000 (Flame red)	RAL 5010, (Gentian blue)
RAL 9010 (foodsafe Pure white)	RAL 9002 (Grey white)	RAL 9006 (White aluminium)
RAL 9001 (foodsafe Cream)	RAL 1019 (Grey beige)	RAL 1015 (Light ivory)
RAL 5015 (Sky blue)	RAL 5014 (Pigeon blue)	RAL 7024 (Graphite grey)

INNER SHELL:
STAINLESS
STEEL



OUTER SHELL:
STAINLESS
STEEL



INNER SHELL:
RAL
COLOUR



OUTER SHELL:
RAL
COLOUR



When configuring the *cool it* SHEV hatch, you can choose from three different **basic materials**:

- **Stainless steel (V2A)**, 0.7–0.8 mm, 1.4301, finish: circular matted (VK), longitudinal grain (VL), duplo finish (VD)
- **Stainless steel (V4A)**, 0.7–0.8 mm, 1.4401, finish: circular matted (VK), longitudinal grain (VL), duplo finish (VD)
- **RAL sheet metal** 0.63–0.75 mm, organically coated panels to DIN EN 10169, basic material S220GD hot-dip galvanised, 25µm polyester coating in RAL colour with protective film. Almost all RAL colours are possible on request.

Material and colour combinations: Depending on the application, the inner and outer shells can be configured as desired. The respective materials and surface finishes can be freely combined.

For planning purposes: In processing areas (hygiene) in the food industry, for example, it may be necessary to make the inner shell of the hatch in stainless steel. However, when configuring the outer shell, which is arranged in the false ceiling, foil-laminated sheet steel in the desired RAL colour can be used for cost/benefit reasons.

Cross-section RWA12

installed in panel ceiling.
The design of the inner and outer shells can be configured as desired.

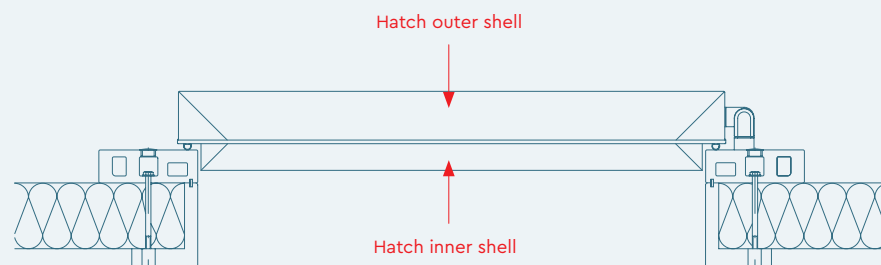

Temperature and mains voltage monitoring for the frame heater

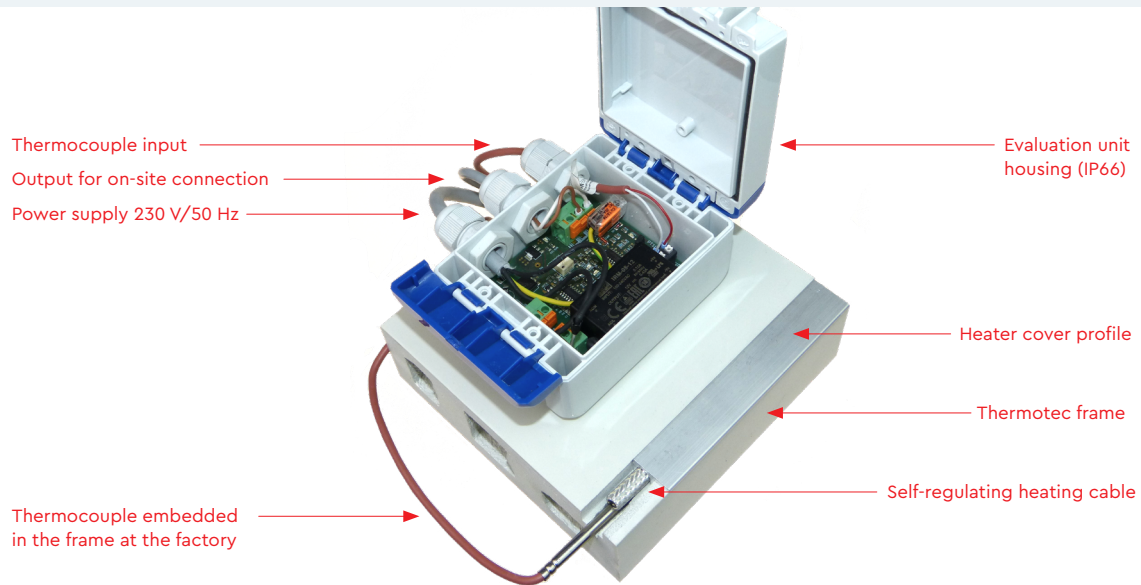

WITH TEMPERATURE AND MAINS VOLTAGE MONITORING



To ensure safe opening of the hatch at all times and to prevent condensation, the *cool it* hatch RWA12H can be equipped with a frame heater. We offer temperature monitoring of the heater to ensure that it is functioning properly at all times.

Technical design: A thermocouple is inserted into the frame underneath the heater, which transmits the actual measured temperature to an evaluation unit. This evaluation unit is pre-mounted on the frame in an IP66 protected housing. No additional supply voltage is required for the evaluation unit; this is drawn directly from the supply line to the frame heater.

Temperature monitoring: If the temperature at the thermocouple falls below the factory-set switching threshold, a potential-free contact is switched which can be evaluated by the customer.

Mains voltage monitoring: In addition, the evaluation unit can detect a drop in the supply voltage and a cable break in the supply line. In such cases, the potential-free contact is also switched.

WITHOUT TEMPERATURE AND MAINS VOLTAGE MONITORING



On-site evaluation: The evaluation unit includes a relay output that offers the following evaluation options:

1. **Changeover contact**
2. **Silent contact/alarm**
3. **Normally open contact**

This covers all eventualities that could lead to a failure or drop in the heating capacity of the hatch.

Technical data

SUPPLY VOLTAGE	230 V/50 Hz
SAFETY CLASS	IP66
ADJUSTMENT RANGE	-5 °C to 15 °C
THERMOCOUPLE	Type PT 100
FEEDBACK CONTACT	potential-free <ul style="list-style-type: none"> • Heater too cold • Voltage drop • Cable break

Hatch dimensions in relation to the aerodynamically effective opening area $[A_a]$

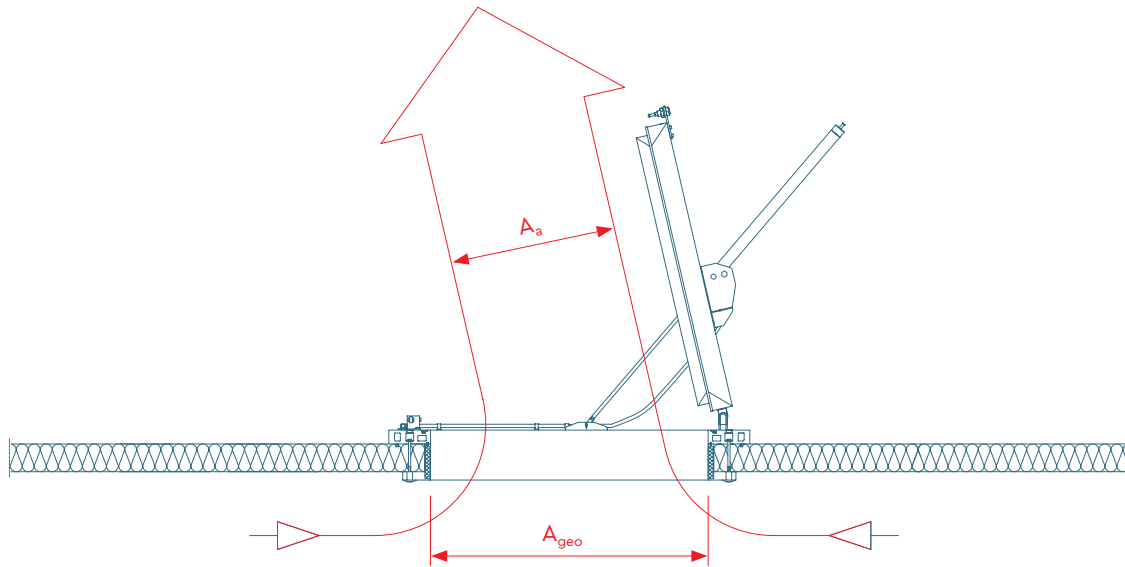

OPENING ANGLE [°]
77°, 63°, 48°, 41°

CLEAR WIDTH CW [MM]
800–1250 mm

CLEAR HEIGHT CH [MM]
800–2500 mm

The option of selecting different opening angles and clear width dimensions for the hatch means that the *cool it* SHEV hatch can be adapted to a wide range of on-site conditions.

The aerodynamic effective opening area $[A_a]$ of the *cool it* SHEV hatch as a natural smoke and heat exhaust vent was determined in a test in accordance with DIN EN 12101-2, Annex B. All available dimensions and opening angles were tested and the corresponding flow coefficient $[C_v]$ determined.

Multiplying the geometric opening area $[A_{geo} = CW \times CH]$ of the hatch by the flow coefficient $[C_v]$ gives the aerodynamically effective opening area:

$$A_a = A_{geo} \times C_v$$

Planning/configuration of the hatch dimensions:

To define the right hatch for your building project, at least the following two values must be known:

- 1: The required aerodynamic opening area for each individual hatch**
- 2: The installation space available on site or the height of the false ceiling**

Note on 1: To configure and order the *cool it* SHEV hatches, the necessary A_a value for each individual hatch must be known. This is the only way to define the correct hatch for your building project.

The A_a value is either specified or can be found in the corresponding fire protection report for the building project. If you are unsure about this point, please contact the relevant specialist planner.

To simplify the selection process, we have created tables for the four opening angles available as standard (77°, 63°, 48°, 41°) in which the corresponding dimensions can be determined directly via the A_a value (see pages 22–23).

Note on 2: The minimum installation space for the available cool it SHEV standard hatches is 95.5 cm between the upper edge of the false ceiling and the lower edge of the roof. If you have less space available, please contact the cool it sales team directly – based on our project

experience, we are able to find custom solutions even for difficult installation situations.

If the distance is greater than 155 cm, any SHEV hatch can be selected.

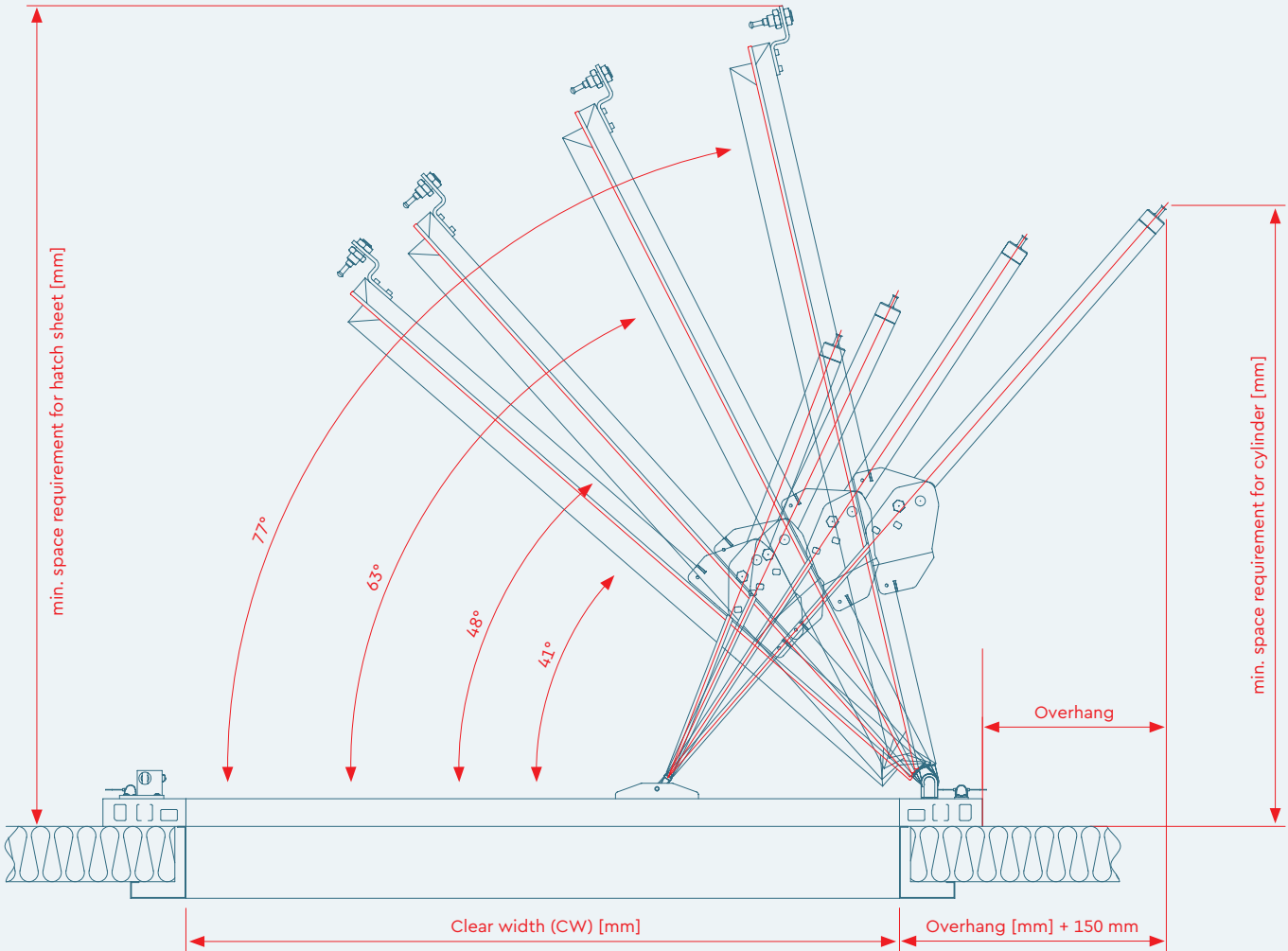

Installation space/space requirement for the hatch

OPENING ANGLE	CYLINDER STROKE [mm]	MIN. SPACE REQUIRED FOR HATCH SHEET [mm]						MIN. SPACE REQUIRED FOR CYLINDER [mm]	OVERHANG [mm]	OVERHANG +150 mm [mm]
		BL 800	BL 900	BL 1000	BL 1100	BL 1200	BL 1280			
77°	600	1045	1140	1240	1335	1435	1530	1200	400	550
63°	500	970	1060	1145	1235	1325	1410	1125	130	280
48°	400	850	925	1000	1075	1150	1225	1025	-150	0
41°	350	780	845	915	980	1045	1115	955	-240	-90

Aerodynamic opening area of an individual hatch

Often, the A_a value required for the construction section exceeds the maximum possible value for a single hatch. For this reason, the required number of systems must

be calculated beforehand during in the planning phase. In addition, the fire protection report may stipulate a certain number or geometric distribution of the systems in the room.

Opening angle 41°

A_a VALUES [m ²]		CLEAR WIDTH [cm]					
		80	≥ 90	≥ 100	≥ 110	≥ 120	≥ 128
CLEAR HEIGHT [cm]	80	0.34	0.39	0.44	0.49	0.55	0.59
	≥ 90	0.37	0.43	0.48	0.53	0.58	0.63
	≥ 100	0.42	0.47	0.53	0.58	0.64	0.69
	≥ 110	0.45	0.51	0.57	0.63	0.69	0.75
	≥ 120	0.49	0.55	0.61	0.67	0.73	0.80
	≥ 130	0.52	0.59	0.65	0.72	0.78	0.83
	≥ 140	0.56	0.63	0.70	0.75	0.82	0.88
	≥ 150	0.59	0.66	0.74	0.81	0.86	0.92
	≥ 160	0.63	0.69	0.77	0.84	0.90	0.96
	≥ 170	0.65	0.73	0.80	0.88	0.94	1.00
	≥ 180	0.69	0.76	0.85	0.93	0.99	1.06
	≥ 190	0.73	0.80	0.89	0.98	1.05	1.12
	≥ 200	0.75	0.85	0.94	1.03	1.10	1.18
	≥ 210	0.79	0.89	0.99	1.06	1.16	1.24
	≥ 220	0.83	0.93	1.01	1.11	1.21	1.30
	≥ 230	0.86	0.95	1.06	1.16	1.27	1.35
≥ 240	0.88	0.99	1.10	1.21	1.32	1.41	
≥ 250	0.92	1.04	1.15	1.27	1.38	1.47	

Opening angle 48°

A_a VALUES [m ²]		CLEAR WIDTH [cm]					
		80	≥ 90	≥ 100	≥ 110	≥ 120	≥ 128
CLEAR HEIGHT [cm]	80	0.36	0.42	0.47	0.52	0.58	0.62
	≥ 90	0.41	0.46	0.52	0.58	0.64	0.69
	≥ 100	0.45	0.50	0.57	0.64	0.70	0.76
	≥ 110	0.49	0.55	0.57	0.68	0.75	0.82
	≥ 120	0.53	0.59	0.67	0.74	0.81	0.88
	≥ 130	0.57	0.64	0.72	0.79	0.86	0.92
	≥ 140	0.60	0.68	0.76	0.83	0.91	0.97
	≥ 150	0.65	0.73	0.81	0.87	0.95	1.02
	≥ 160	0.68	0.76	0.85	0.93	1.02	1.06
	≥ 170	0.72	0.81	0.88	0.97	1.04	1.11
	≥ 180	0.76	0.84	0.94	1.03	1.10	1.18
	≥ 190	0.79	0.89	0.99	1.07	1.16	1.24
	≥ 200	0.83	0.94	1.02	1.12	1.22	1.31
	≥ 210	0.87	0.96	1.07	1.18	1.29	1.37
	≥ 220	0.90	1.01	1.12	1.23	1.35	1.41
	≥ 230	0.94	1.06	1.17	1.27	1.38	1.47
≥ 240	0.96	1.08	1.20	1.32	1.44	1.54	
≥ 250	1.00	1.13	1.25	1.38	1.50	1.60	

This is typically the case, for example, if smoke dissipation is obstructed by fixtures in the room, such as high shelves. In this case, the required A_a value must be apportioned to multiple hatches.

A_a [m ²]	≥ 0.75 m ² to ≤ 0.99 m ²
	≥ 1.00 m ² to ≤ 1.49 m ²
	≥ 1.50 m ² to ≤ 1.99 m ²
	≤ 2.00 m ²

Opening angle 63°

A_a VALUES [m ²]		CLEAR WIDTH [cm]					
		80	≥ 90	≥ 100	≥ 110	≥ 120	≥ 128
CLEAR HEIGHT [cm]	80	0.40	0.45	0.51	0.56	0.62	0.67
	≥ 90	0.45	0.51	0.57	0.63	0.69	0.74
	≥ 100	0.50	0.56	0.63	0.69	0.76	0.81
	≥ 110	0.55	0.61	0.68	0.76	0.83	0.89
	≥ 120	0.60	0.67	0.74	0.82	0.89	0.95
	≥ 130	0.63	0.71	0.79	0.89	0.97	1.03
	≥ 140	0.68	0.77	0.85	0.94	1.02	1.09
	≥ 150	0.73	0.82	0.92	0.99	1.08	1.15
	≥ 160	0.77	0.86	0.96	1.06	1.15	1.23
	≥ 170	0.82	0.92	1.02	1.10	1.20	1.28
	≥ 180	0.86	0.97	1.08	1.17	1.27	1.36
	≥ 190	0.91	1.03	1.14	1.23	1.35	1.43
	≥ 200	0.94	1.06	1.18	1.30	1.42	1.51
	≥ 210	0.99	1.12	1.24	1.34	1.46	1.56
	≥ 220	1.04	1.17	1.30	1.40	1.53	1.63
	≥ 230	1.09	1.22	1.36	1.47	1.60	1.71
≥ 240	1.11	1.25	1.39	1.50	1.64	1.75	
≥ 250	1.16	1.31	1.45	1.57	1.71	1.82	

Opening angle 77°

A_a VALUES [m ²]		CLEAR WIDTH [cm]					
		80	≥ 90	≥ 100	≥ 110	≥ 120	≥ 128
CLEAR HEIGHT [cm]	80	0.42	0.48	0.53	0.59	0.64	0.69
	≥ 90	0.48	0.53	0.59	0.66	0.72	0.77
	≥ 100	0.52	0.59	0.65	0.73	0.79	0.84
	≥ 110	0.57	0.64	0.72	0.80	0.87	0.93
	≥ 120	0.62	0.70	0.78	0.86	0.94	1.00
	≥ 130	0.67	0.75	0.83	0.93	1.01	1.08
	≥ 140	0.72	0.81	0.90	0.99	1.08	1.15
	≥ 150	0.77	0.86	0.96	1.06	1.15	1.23
	≥ 160	0.81	0.91	1.01	1.11	1.21	1.29
	≥ 170	0.86	0.96	1.07	1.18	1.29	1.37
	≥ 180	0.91	1.02	1.13	1.25	1.36	1.45
	≥ 190	0.96	1.08	1.20	1.32	1.44	1.53
	≥ 200	1.01	1.13	1.26	1.39	1.51	1.61
	≥ 210	1.06	1.19	1.32	1.46	1.59	1.69
	≥ 220	1.11	1.25	1.39	1.52	1.66	1.77
	≥ 230	1.16	1.30	1.45	1.59	1.74	1.85
≥ 240	1.21	1.36	1.51	1.66	1.81	1.94	
≥ 250	1.26	1.42	1.58	1.73	1.89	2.02	

Swivel range of the door leaf

The swivel ranges shown here represent the minimum installation spaces necessary to prevent collisions on site. Accessibility for assembly and maintenance work must be

taken into account! Tolerances are not shown! Depending on the building project, additional tolerances may need to be taken into account.

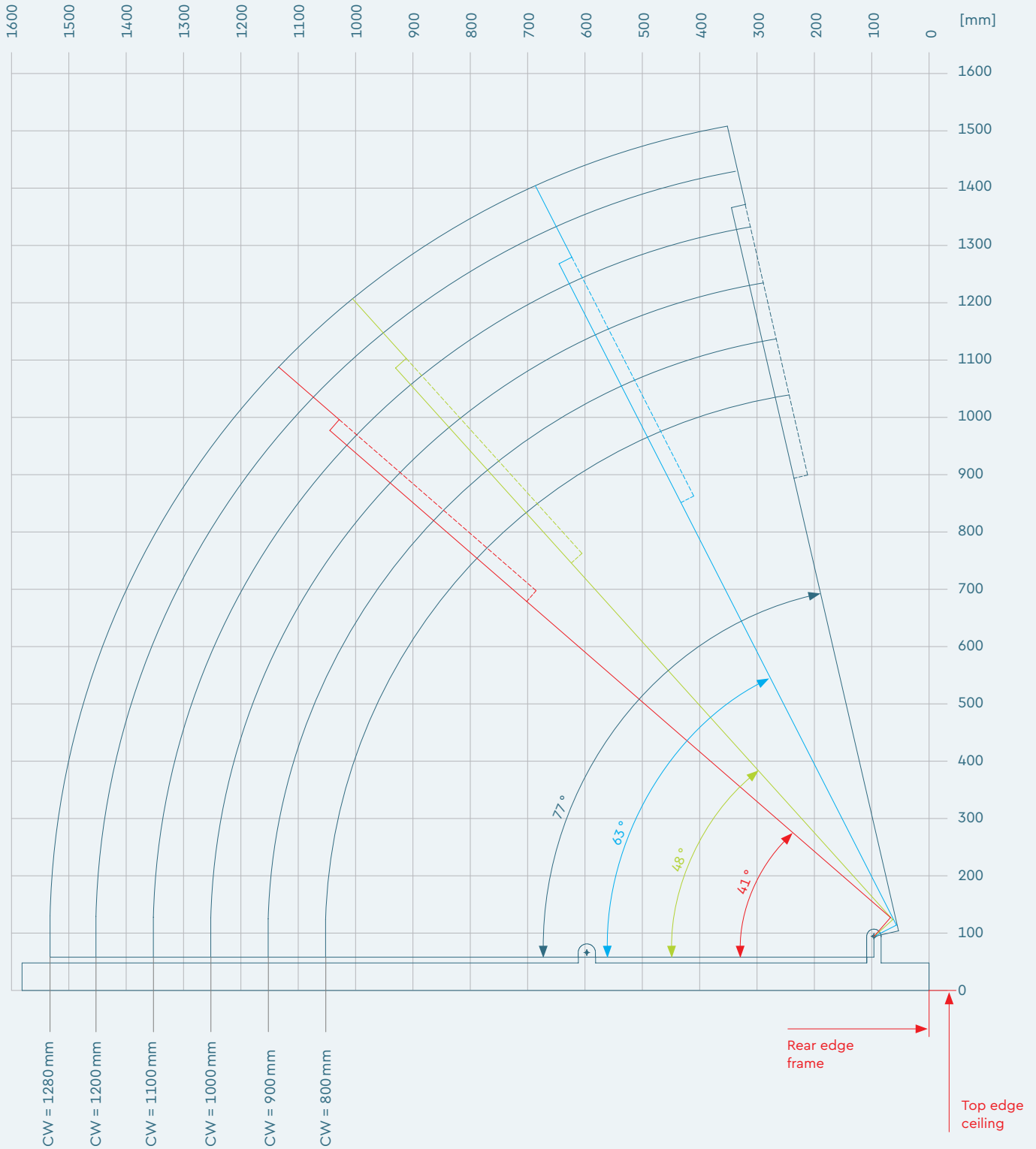

Cylinder swivel range

CYLINDER END POINTS [mm]				HIGHEST POINT [mm]	
Opening angle	Cylinder stroke	X	Y	X	Y
41°	350 mm	-180	+945	/	/
48°	400 mm	-85	+1010	/	/
63°	500 mm	+135	+1100	+70	+1100
77°	600 mm	+395	+1140	+100	+1185

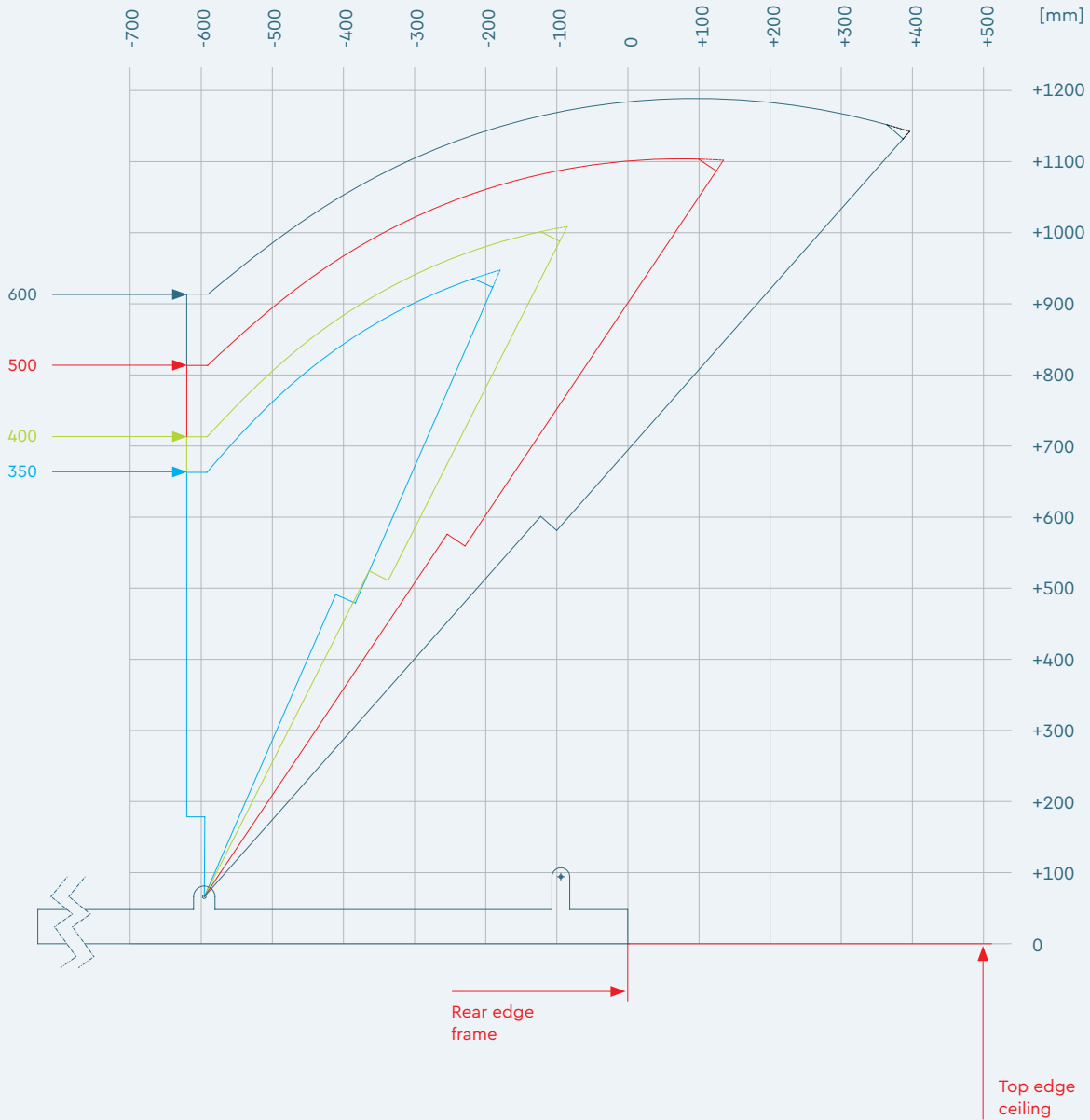

Door contact switch for feedback signal ("hatch open" or "hatch closed")



WITHOUT



HATCH OPEN

HATCH
CLOSEDHATCH OPEN +
HATCH CLOSED

To monitor the position of the hatch, the cool it SHEV hatch can be equipped with **two different door contact switches**: Both the "hatch closed" contact switch to query the closed position and the "hatch open" contact switch to query the fully open position are available.

The switches are available in **any combination**. You can order the hatch without any switches, with only one or with both.

For planning purposes: There are many systems or queries that require a signal in order to determine the hatch position, below are some examples:

- Combination with a mechanical smoke extraction system:** If you plan to implement your construction project using a mechanical smoke extraction solution, it is essential that you read *Appendix 2* of this brochure. Please also request our information material on *risk assessments for mechanical smoke ventilation in combination with SHEV hatches*. In this case, the "Hatch open" feedback contact should be switched to send a signal to the control unit for the smoke gas ventilators.
- Refrigeration system/evaporator:** The evaporators in a cold store or freezer room have a negative effect on the flow of rising fire gases due to their built-in fans. For this purpose, the "hatch closed" feedback contact can be connected to the control unit of the refrigeration system so that the latter is deactivated in case of fire.
- Indication of correct closure of all hatches:** The "Hatch closed" contact switch can be polled to determine whether the hatch is correctly closed and to ensure that opening the hatch does not cause condensation or ice formation in the vicinity of the hatch. Especially in rooms with high ceilings, it is difficult to see whether the hatches are still slightly open.
- Hatch opening/thermal release indication:** If the hatch has an autonomously operating CO₂ release as shown in *variant 1, selection 9*, it can be determined via the "Hatch open" contact switch whether the corresponding hatch has been thermally triggered. This triggering can be particularly useful for large storage areas, where the open status of each hatch can be displayed centrally on a corresponding panel.

Technical data

	HATCH OPEN OPTION	HATCH CLOSED OPTION
TYPE	Door contact switch for polling of "hatch open" 1	Door contact switch for polling of "hatch closed"
ITEM NUMBER	52-021	52-006
RATED INSULATION VOLTAGE	$U_i = 500 \text{ V}$	$U_i = 400 \text{ V}$
RATED IMPULSE WITHSTAND VOLTAGE	$U_{imp} = 6 \text{ kV}$	$U_{imp} = 4 \text{ kV}$
CONTINUOUS THERMAL CURRENT	$I = 10 \text{ A}$	$I = 6 \text{ A}$
SAFETY CLASS	IP67 in accordance with ICE/EN 60529	
UTILIZATION CATEGORY	AC-15 230 V/4 A, AC-13 24 V/1 A	AC-15 230 V/6 A, AC-13 24 V/1 A
TYPE OF CIRCUIT	Normally Closed (NC)/Normally Open (NO)	
CONNECTION CROSS-SECTION	0.75 mm ² – 2.5 mm ²	max. 2.5 mm ² (incl. end sleeves)
TEMPERATURE RANGE	-30 °C to +80 °C	-20 °C to +80 °C
LOAD APPLICATION	M20 × 1.5	
SWITCHING SYSTEM		Snap-action
REGULATIONS	EN ISO 13849-1, EN 60947-5-1, BG-GS-ET-15	

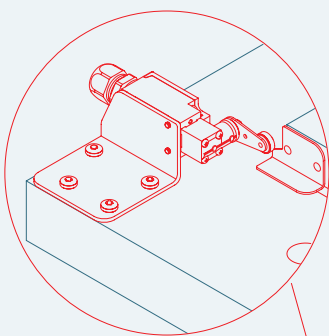
**Hatch Open option**

Door contact switch/
"hatch open" feedback
contact. Roller switch on
the tape side of the hatch.

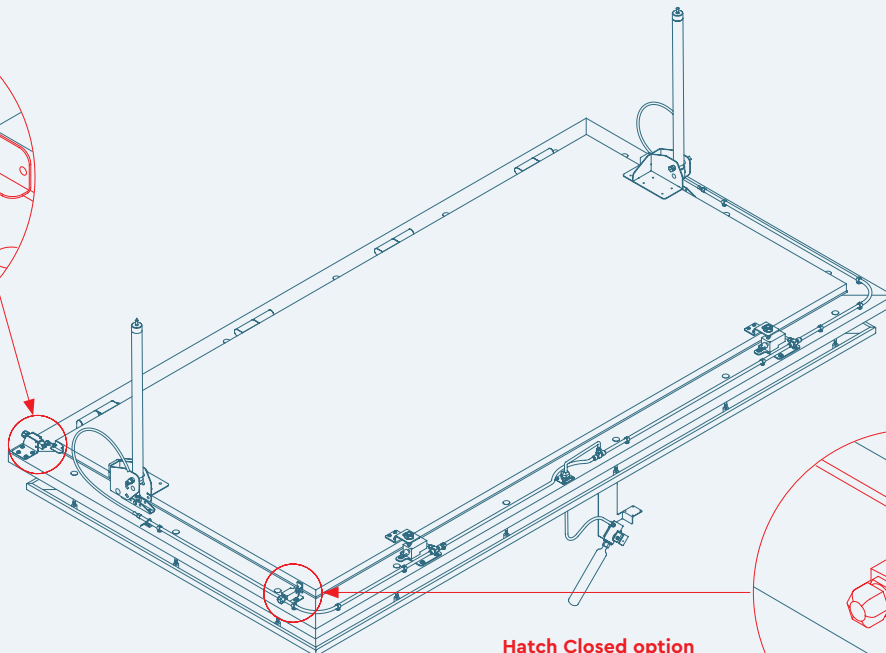
**Hatch Closed option**

Door contact switch/
"hatch closed" feedback
contact. Roller switch on
the closing side of the hatch.

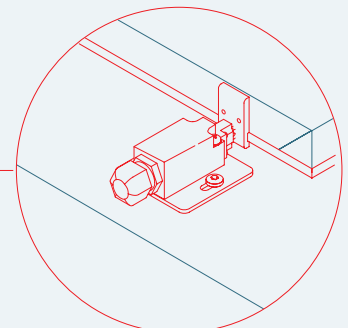

Fall-arrester collective protection system to DIN EN 13374:2013, DIN EN ISO 14122-3:2002



WITH FALL-ARRESTER COLLECTIVE PROTECTIVE GRATING



In order to prevent a fall through the open hatch after a release, we offer a **fall-arrester in the form of an approved railing**, which is supplied in a ready-for-use condition. Crucially, the system has **approval for mounting on foamed panels** and can therefore be used safely on any standard panel ceiling in cold stores and freezer rooms.

The available collective protection system has been tested in accordance with DIN EN 13374:2013 and DIN EN ISO 14122-3:2002.

Retrofitting: This system can be retrofitted to any existing *cool it* SHEV hatch. Please contact us for a tailored quotation.

Why don't we offer fall-through protection like all other NSHEV manufacturers?

Unlike conventional SHEV systems, the *cool it* SHEV hatch does not need to be opened for maintenance work. All mechanical components are located on the top of the hatch. This means that they can be reached from the false ceiling with the hatch closed and can thus be safely inspected, replaced and serviced. A theoretical fall-through is therefore only possible after a test release or regular release.

WITHOUT FALL-ARRESTER COLLECTIVE PROTECTIVE GRATING



Fall-through protection within the clear dimensions of the hatch is not possible without additional structural measures to reinforce the false ceiling, as the statics of a standard panel ceiling are not able to absorb the forces that would occur. For example, a steel replacement would have to be installed under each hatch to safely dissipate these forces. Since *cool it* has no influence on the statics of the ceiling construction, we do not offer such systems.

Furthermore, the necessary static measures would probably result in additional costs that would exceed the price of the collective protection system. In order to circumvent the problems described above, we offer a different type of collective protection system whose function is not influenced by the statics of the panel ceiling and therefore does not require any additional reinforcement measures on site.

Views

top: Side views with panel ceiling
below: Top view

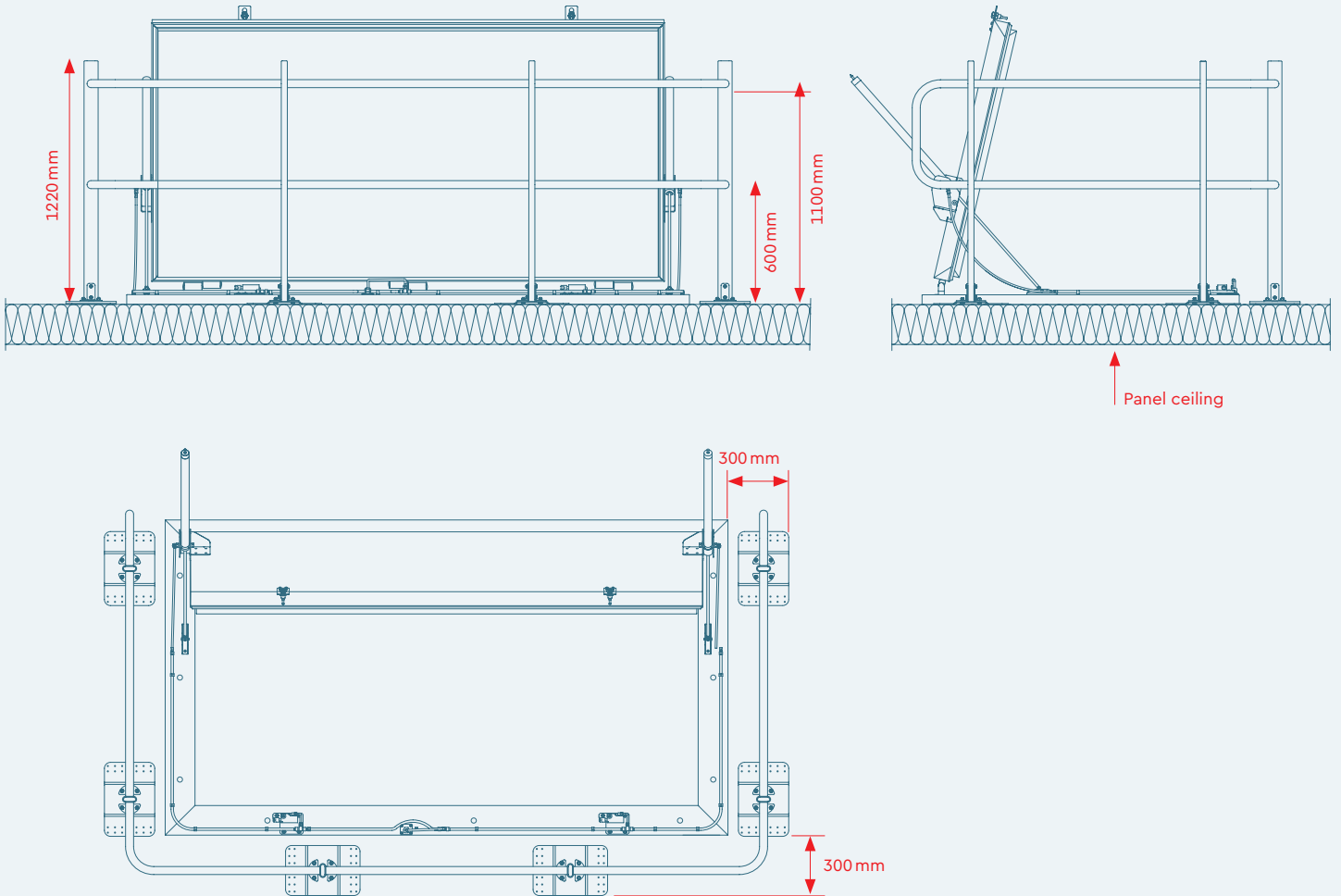

Collective protection system

left: Base plate for mounting the railing on a panel ceiling
right: customised for the corresponding hatch size



Fire safety switch (FSS) to DIN VDE 0100-420, only for RWA12H

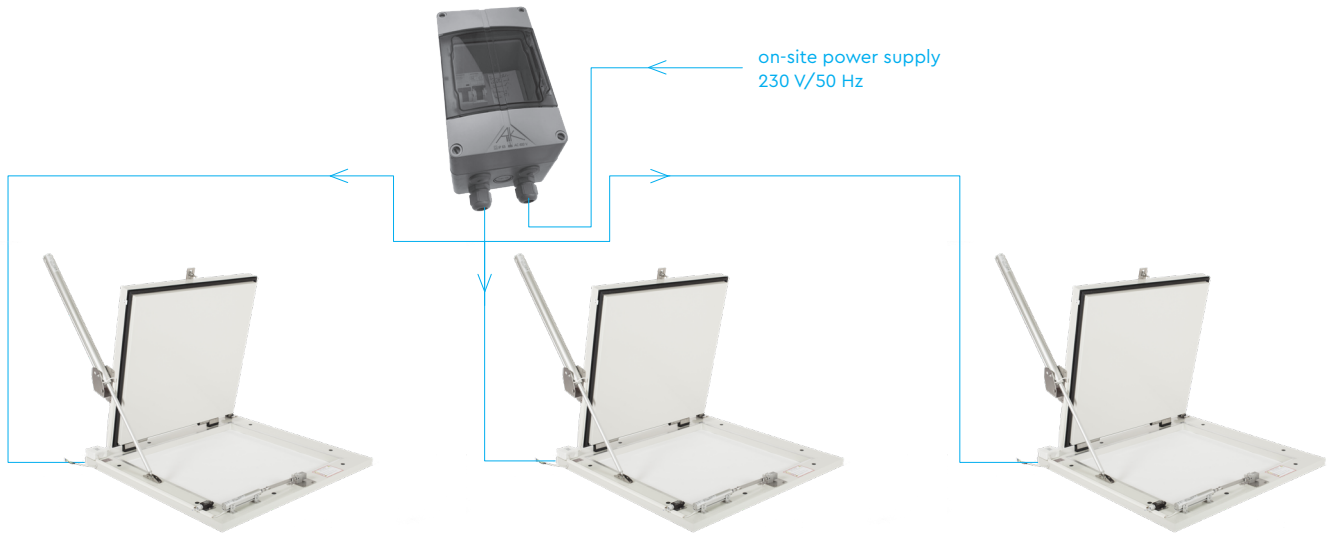

WITHOUT FIRE SAFETY SWITCH

FIRE SAFETY SWITCH +
RESIDUAL CURRENT
DEVICE/CIRCUIT BREAKER

FIRE SAFETY SWITCH +
CIRCUIT BREAKER

As an option for the cool it hatch RWA12/RWA12H: Fire safety switch (FSS) to DIN VDE 0100-420

The *International Electrotechnical Commission* and the *German Standardization Institute (DIN)* recommend the use of a fire safety switch (FSS) as good engineering practice. Since 2016, the use of such a device in certain applications has been set out in DIN VDE 0100, part 420. Upon expiry of a transitional period on 18/12/2017, their installation will be obligatory in many facilities.

In the past, the available protective mechanisms (circuit breaker and residual current device) did not provide adequate protection against hazardous arc faults, whether serial or parallel in nature. The FSS extends these systems and consequently reduces the probability of fires resulting from electrical causes.

At *cool it*, the FSS is optionally available to protect the heating circuits. It is recommended to take account of this type of safety mechanism when planning and installing *cool it* hatches of type RWA12. The FSS is supplied in a separate box and is therefore suitable for use in new installations or in retrofit installations. It is supplied as a unit with another safety mechanism.

Two variants are available:

1. **Fire safety switch + residual current device/circuit breaker (combination circuit breaker).**
2. **Fire safety switch + circuit breaker if the required residual current device is already provided by the customer upstream in the building.**

For planning purposes, not every hatch necessarily has to be equipped with a fire safety switch. On the technical side, the power consumption per FSS must not exceed 1000 W.

$$\text{Power consumption [W]} = (2 \times \text{CH [m]} + 2 \times \text{CW [m]}) \times 50 \text{ W} \leq 1000 \text{ W}$$

A standard hatch in the format 128 cm × 250 cm has a calculated power consumption of 380 W. Accordingly, at least two hatches can be connected to one FSS. For the exact dimensioning, please contact us or consult a specialist planner.

Design variants/signal transmission/interconnections on site

TYPE OF INSTALLATION			TRIGGERING THE RWA12/RWA12H				SIGNAL TRANSMISSION TO AN ALARM BOX TO OPEN ADDITIONAL HATCHES		
Cold store $\geq 4^{\circ}\text{C}$	Freezer room $< 4^{\circ}\text{C}$	Wet cleaning	Self-triggering via TAG with fire detection element	Electric remote triggering 24 V via TAG	On-site CO ₂ release via TAG shuttle valve	On-site CO ₂ release via alarm box on hatch	Pneumatic signal from TAG to on-site alarm box	Electrical signal via pressure switch to on-site alarm box	Electrical signal from smoke or heat maximum detector
Variant 1			•						
Variant 2			•	•					
Variant 3			•		•				
Variant 4			•		•		•		
Variant 5			•		•			•	
Variant 6									•
	Variant 7		•						
	Variant 8		•	•					
	Variant 9					•	•		
	Variant 10							•	
	Variant 11								•
		Variant 12							•

There are many ways to integrate the *cool it* SHEV hatches into the overall system on site. Below are **some design examples for the specialist areas of cold stores, freezer rooms and wet cleaning.**

The hatches are prepared as per the variant and can be connected directly on site.

SHEV buttons, SHEV control units and CO₂ alarm boxes as well as all electrical cables and CO₂ piping that are not mounted directly on the hatch are not included in the scope of delivery.

Some of these components can be found under *Accessories (from page 36)* in this brochure. Alternatively, please contact our sales team so that we can provide you with a tailored quotation. This is necessary because many system components can supply more than one *cool it* SHEV hatch, or there may be (for example) connections from multiple hatches to trigger groups.



**Thermal triggering
of a single hatch**

The fire detection element in the TAG is triggered when the specified temperature is reached, opening the hatch.

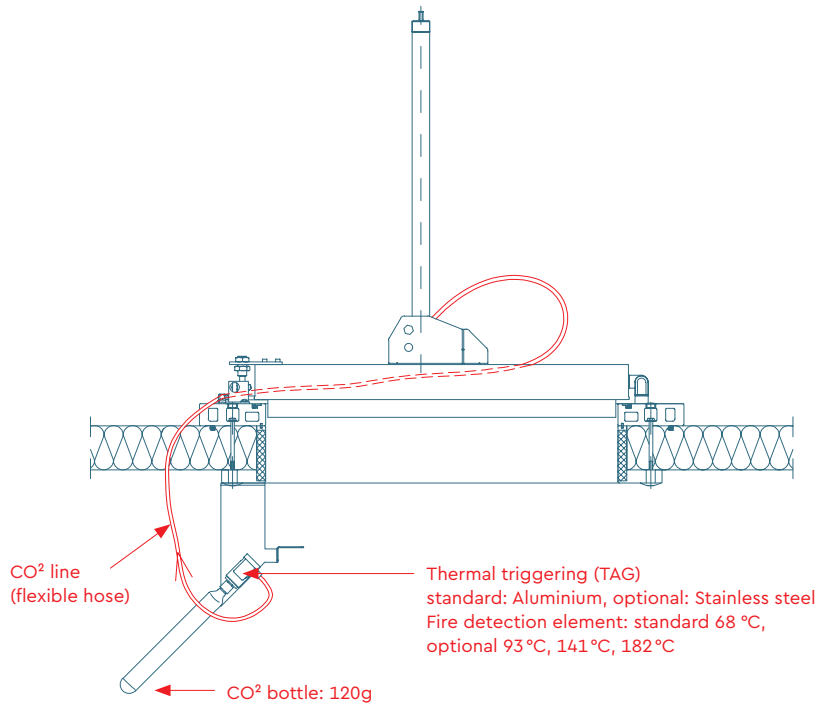

**Thermal triggering
of a single hatch**

The fire detection element in the TAG is triggered when the specified temperature is reached, opening the hatch.

24 V electrical triggering

An on-site 24 V signal triggers a solenoid which destroys the fire detection element.

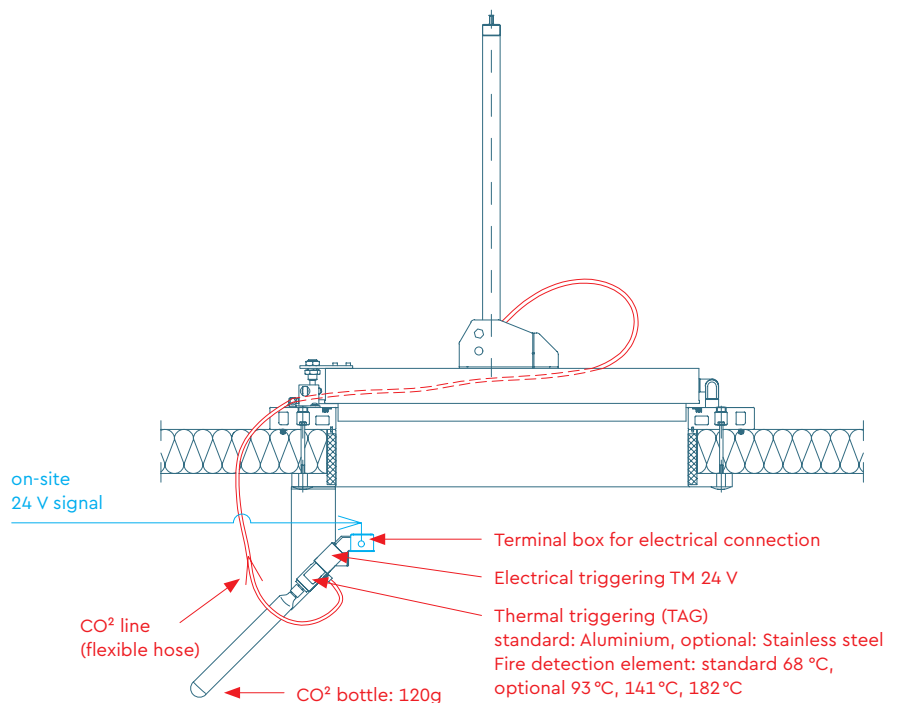



Thermal triggering of a single hatch

The fire detection element in the TAG is triggered when the specified temperature is reached, opening the hatch.

Group triggering via alarm box

Manual triggering of the group via the manual lever on the alarm box

optional: Electrical remote release 12 V/24 V/48 V/230 V

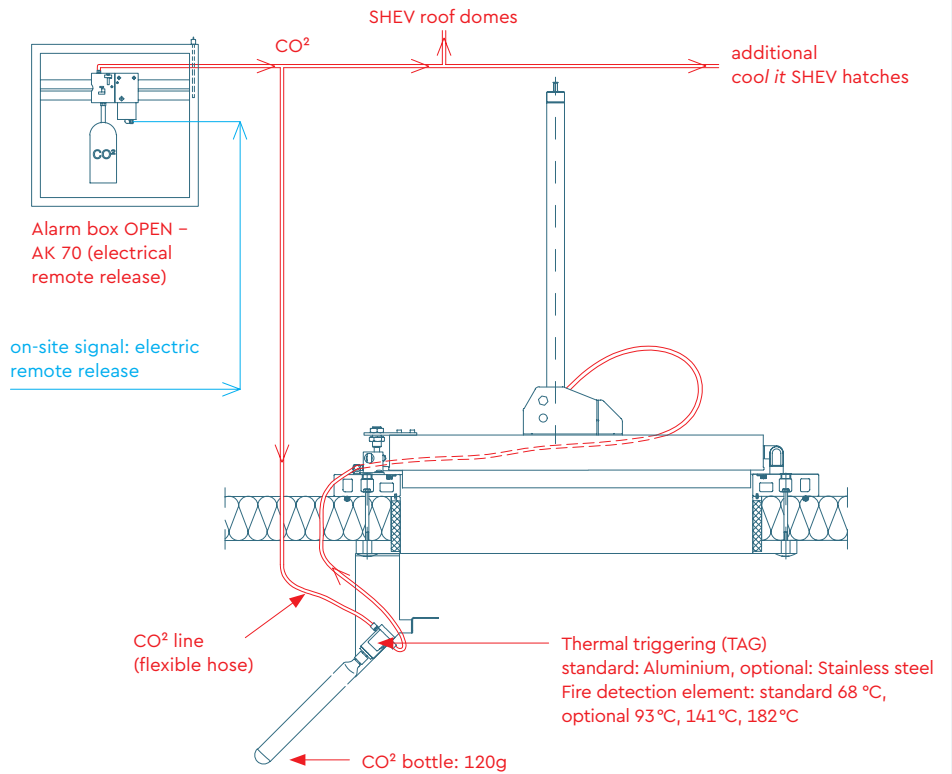

Thermal triggering of a single hatch

The fire detection element in the TAG is triggered when the specified temperature is reached, opening the hatch.

Group triggering

Thermal group triggering via alarm box The TAG additionally triggers the alarm box and opens the group.

Manual group triggering by means of a manual lever on the alarm box

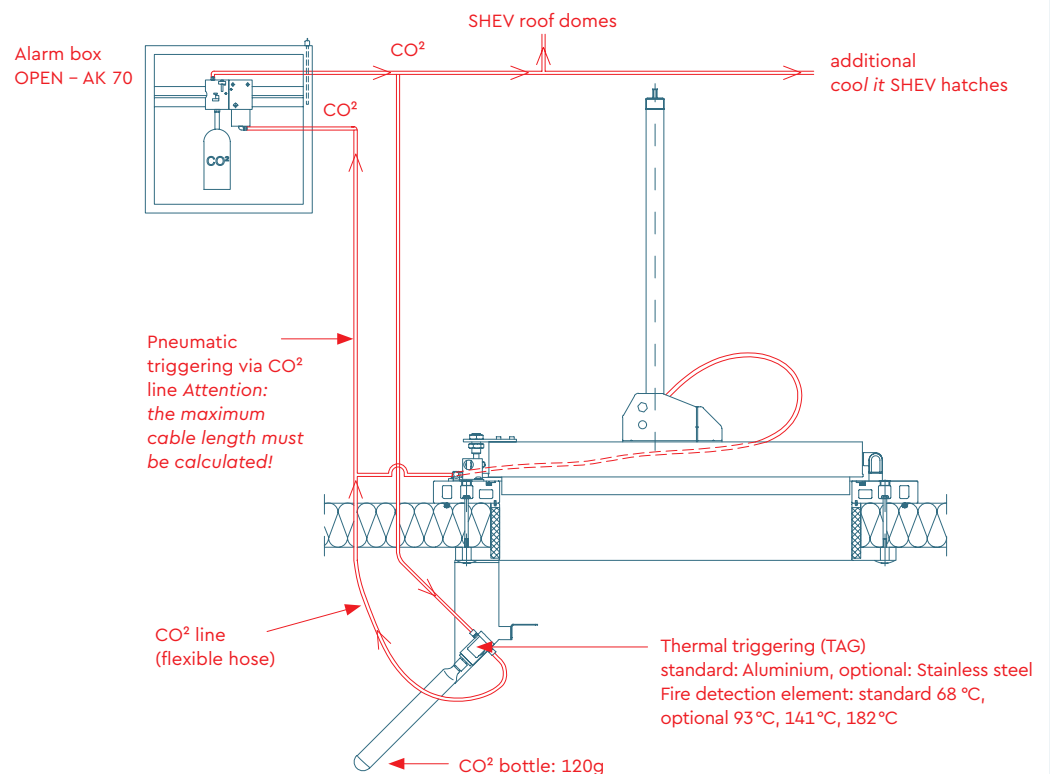



Thermal triggering of a single hatch

The fire detection element in the TAG is triggered when the specified temperature is reached, opening the hatch.

Group triggering via alarm box

Manual triggering of the group via the manual lever on the alarm box

Automatic group triggering

The TAG activates the group after thermal triggering via a pressure switch.

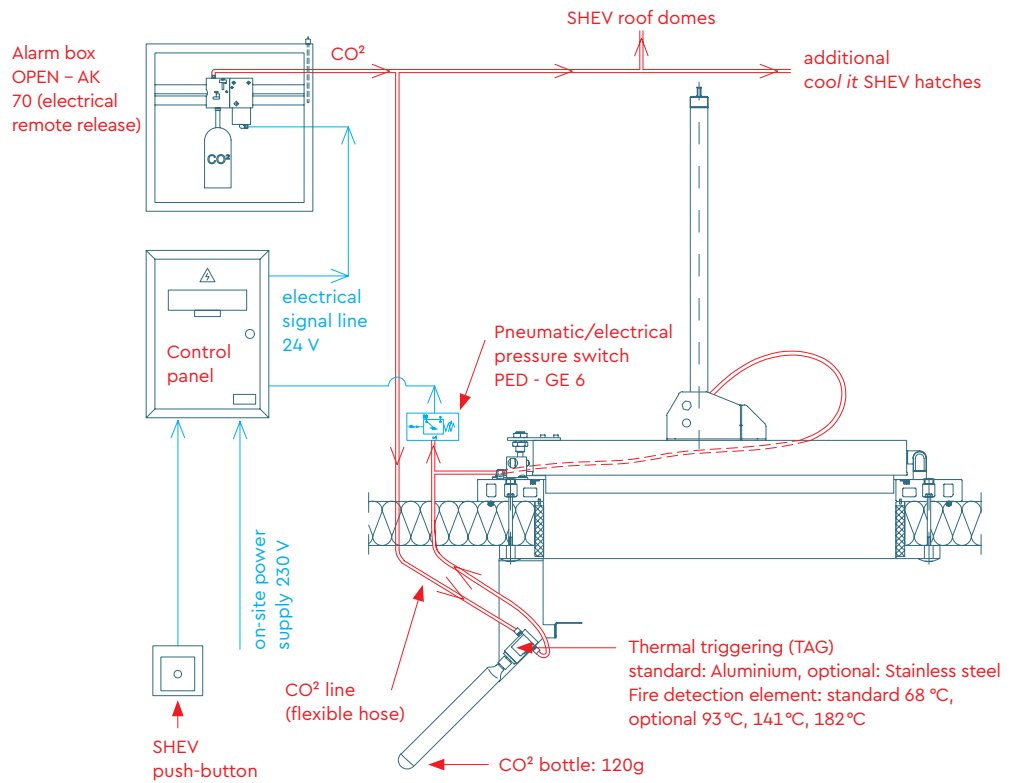

Group triggering via heat detector

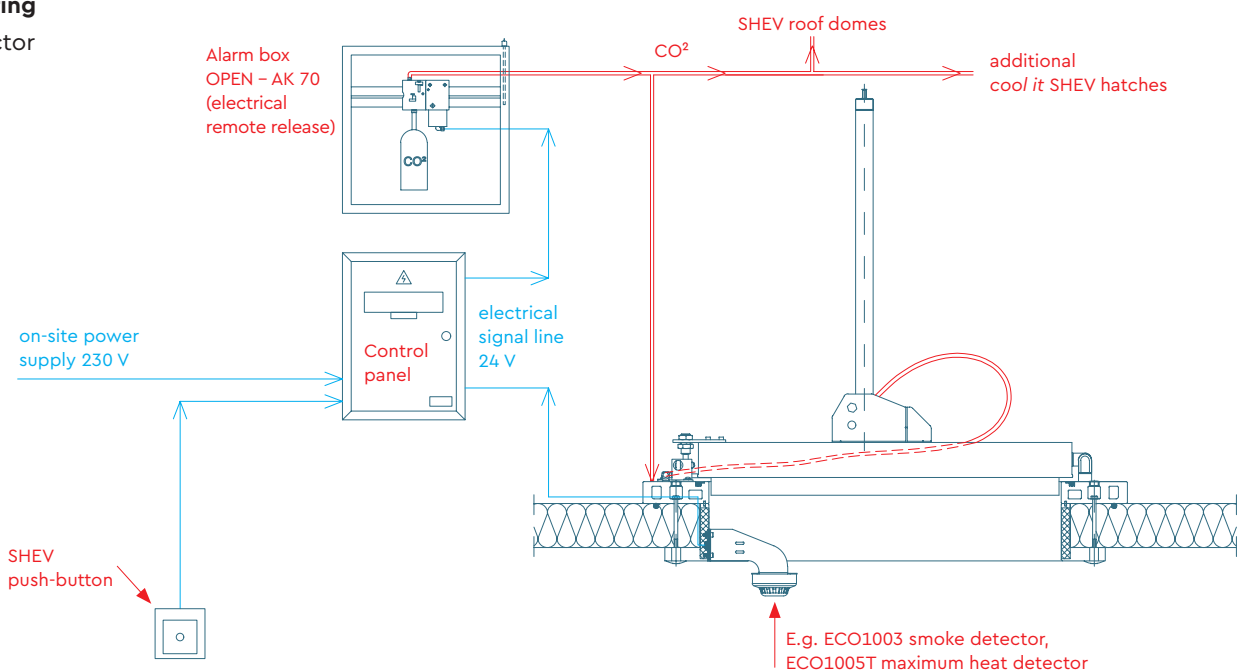



**Thermal triggering
of a single hatch**

The fire detection element in TAG 1 triggers when the specified temperature is reached and activates TAG 2 via the pneumatic release cylinder (PRC), opening the hatch.

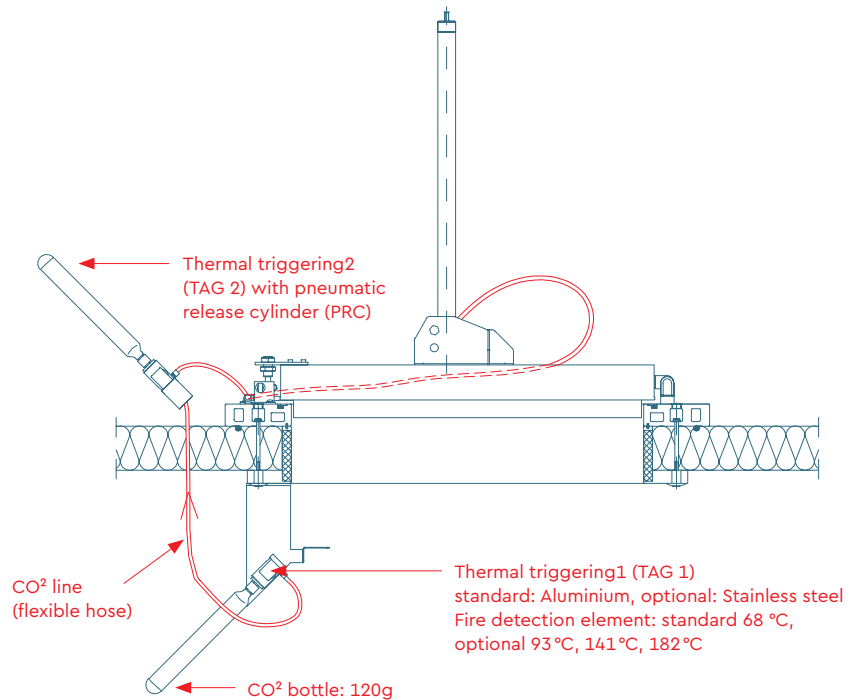

**Thermal triggering
of a single hatch**

The fire detection element in TAG 1 triggers when the specified temperature is reached and activates TAG 2 via the pneumatic release cylinder (PRC), opening the hatch.

24 V electrical triggering

An on-site 24 V signal triggers a solenoid which destroys the fire detection element.

Only approved down to -20 °C.

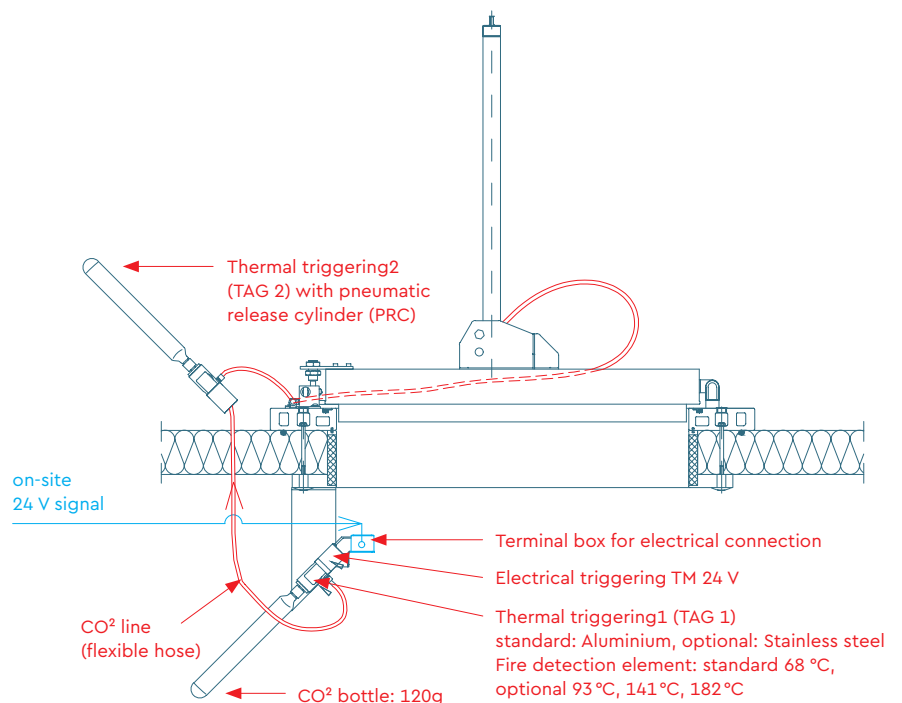



Group triggering

Thermal group triggering via alarm box The TAG additionally triggers the alarm box pneumatically and opens the group.

Manual group triggering by means of a manual lever on the alarm box

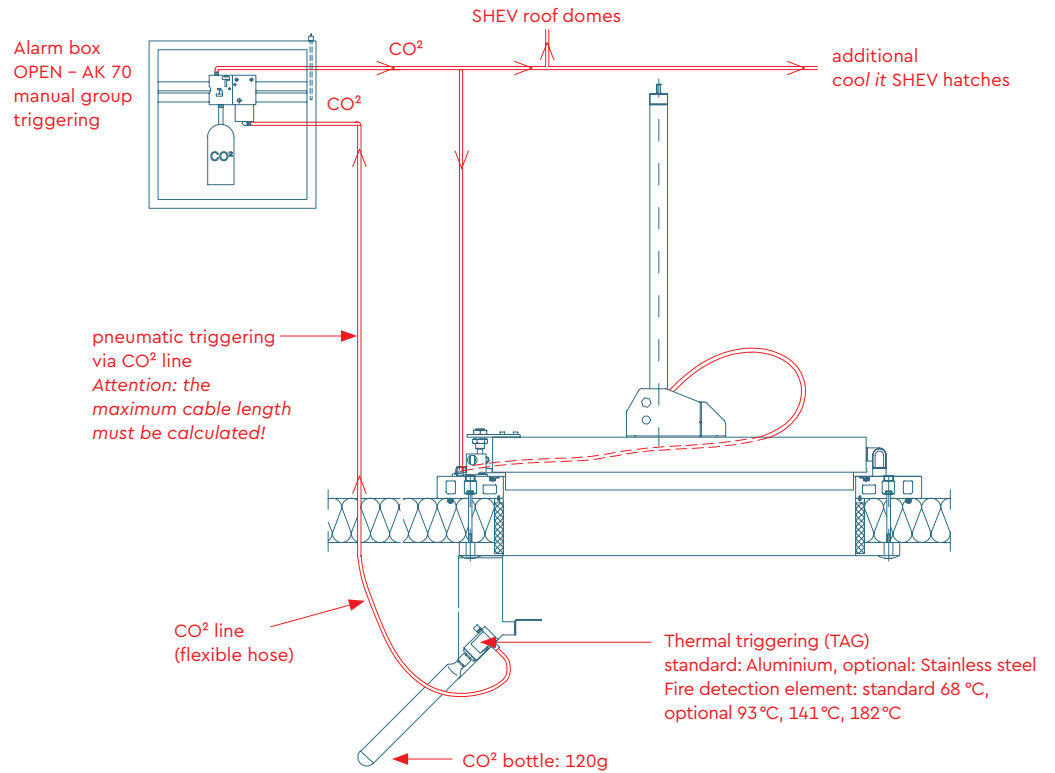

Group triggering via alarm box

Manual triggering of the group via the manual lever on the alarm box

Automatic group triggering

The TAG activates the group after thermal triggering via a pressure switch.

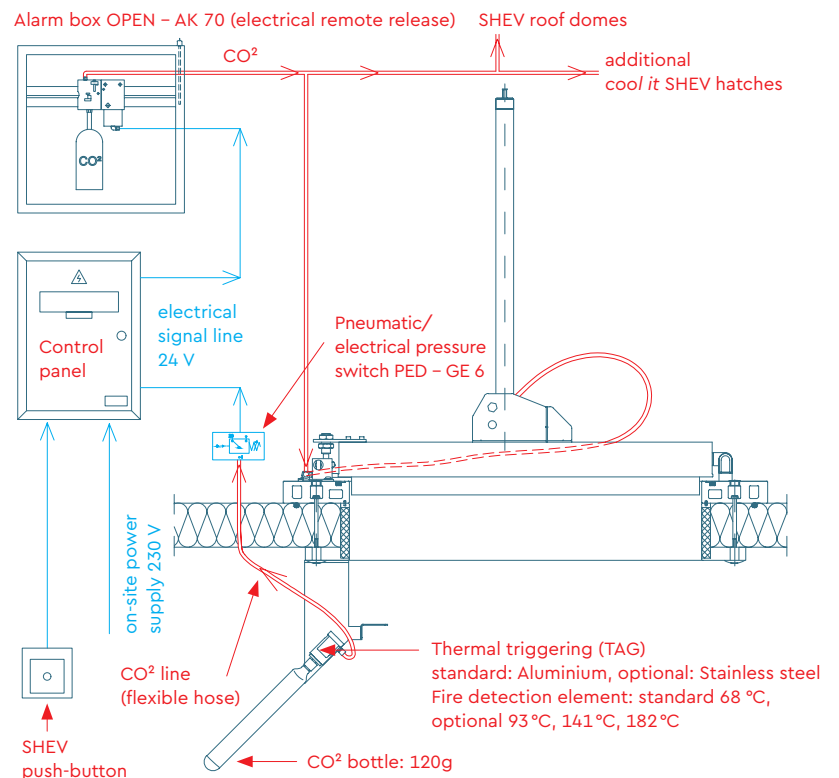



Group triggering
via heat detector

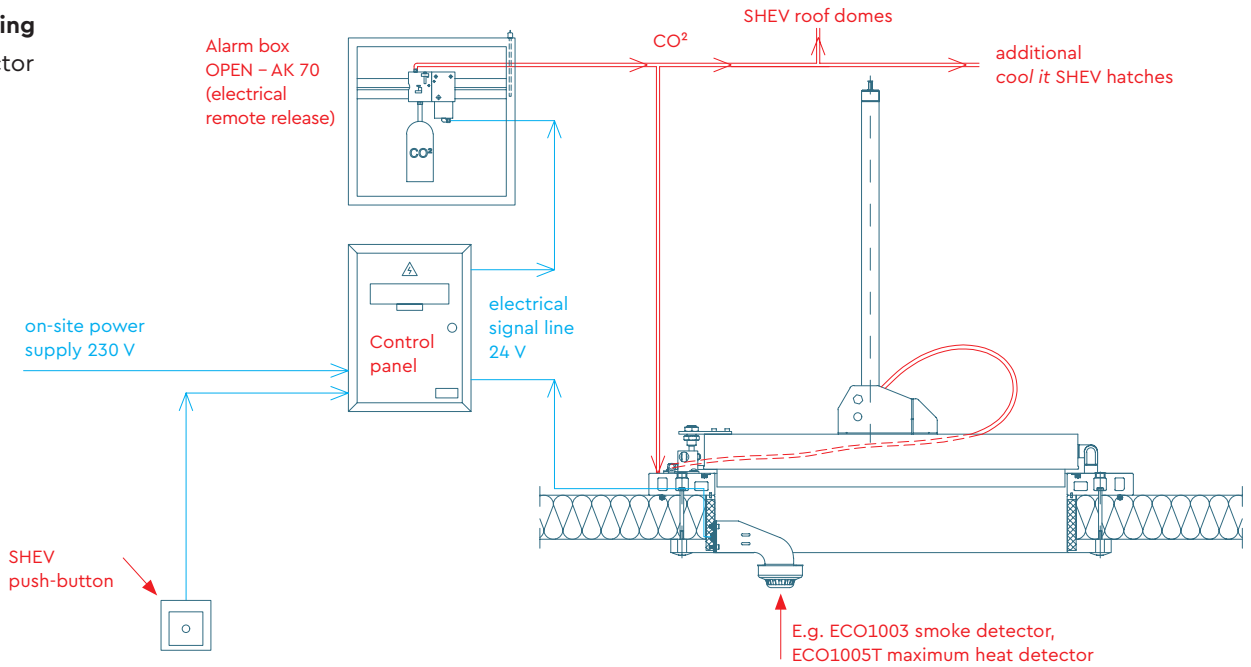

Group triggering
via heat detector

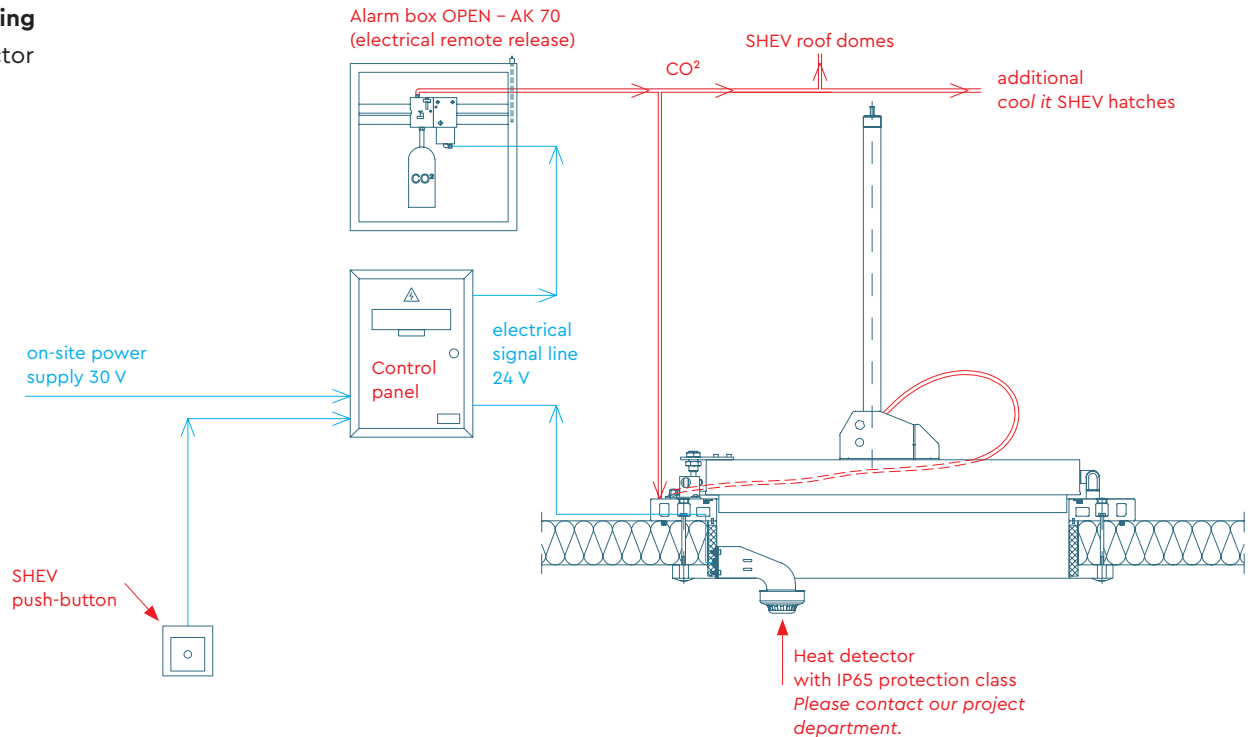



24 V SHEV control panel with emergency power supply³⁶ in case of mains failure to DIN EN 12101-10:2003

The **24 V SHEV control panel is a smoke and heat ventilation control unit with backup power supply allowing for 72 hours of operation in the event of a mains power failure.**

It is used to open and close the *cool it* SHEV hatches.

Important for RWA12H: The backup power supply for the frame heater must be provided and monitored by the customer.

The type EN control panels available from us comply with the valid European standard DIN EN 12101-10. This standard specifies the requirement for a redundant power supply in the case of natural smoke and heat ventilation.

Two equivalent sources of energy are installed in this control panel version: a powerful power supply unit and rechargeable batteries.

The power supply unit is powerful enough to cover the maximum peak loads that may occur. The SHEV hatch is operated by the rechargeable batteries only if the 230 V power supply fails. The employed rechargeable batteries are dimensioned in such a way that they can ensure a backup power supply for 72 hours and then still open the connected hatches twice and close them once.

Attention: Control panels that are not redundantly configured are also available on the market. With these devices, the function of the system cannot be fulfilled if the batteries fail. As a result, the actuators cannot move and the hatch does not open in the event of a fire!

For planning purposes: If your building project includes more than one hatch then a **custom-designed control panel** can be created for you. For this, the following information is essential:

- Situation plan of the hatches and required installation location of the control panel. Alternatively: Distance between the control panel and each individual hatch in metres
- Number of trigger groups (e.g. total of four hatches: If all four hatches are to open at once then there is a single trigger group. If only two hatches are to be triggered by any one push-button then there are two trigger groups.)

Examples of the combination or interconnection of central and pneumatic RWA12 hatches can be found under *selection 9*.

Since the supply voltage is 24 V direct current, the dimensioning of the cable cross-sections depends on the current intensity and the cable length. We will be happy to advise you on the dimensioning of all system components and their geometric arrangement in your building project.



Technical data

TYPE	EN 230 V/24 V 10 A-2-1
POTENTIAL-FREE CONTACTS	"SHEV triggered", "Malfunction"
INPUTS	for CIE contact (Central Indicating Equipment)
NUM. AUTOMAT. DETECTORS	max. 50 units ECO 1003/ECO 1005T
NO. SHEV PUSH-BUTTONS	max. 10 units
NUMBER OF TRIGGER GROUPS	1
BOX	Sheet steel box with sash lock, greyish white (similar to RAL 7035)
DIMENSIONS	380 mm × 380 mm × 210 mm
WEIGHT	10.8 kg
NOMINAL BATTERY CAPACITY	7.2 Ah
NOMINAL BATTERY VOLTAGE	24 V (2 × 12 V)
NOMINAL OUTPUT	230 V AC/32 VA
TEMPERATURE RANGE	Temperature class 3 in accordance with VdS 2581 (-5 °C to +40 °C) Temperature class 3 in accordance with VdS 2593 (-5 °C to +40 °C)
CERTIFICATE TEST NUMBER	R 60025243
NOMINAL OUTPUT	230 V AC/32 VA

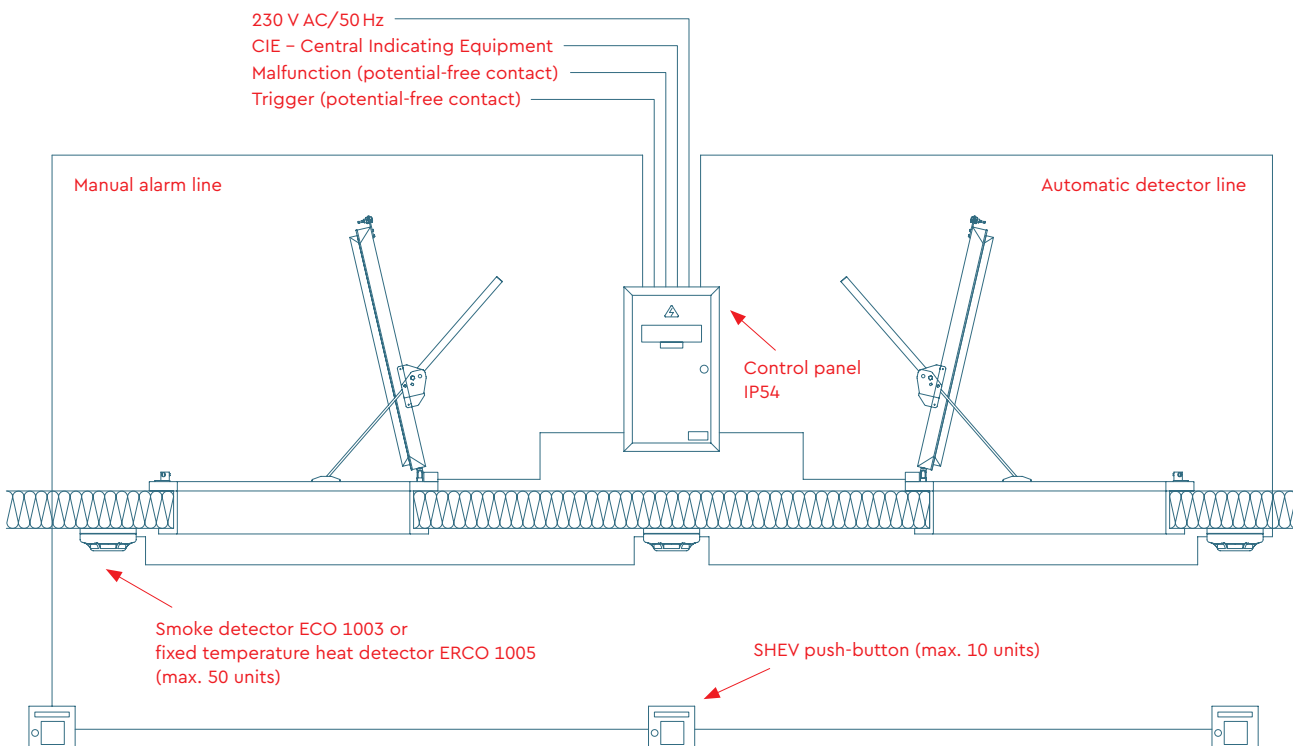



Optional SHEV button with weather protection cover, protection class IP54

The pulse that causes the SHEV hatches to open can be triggered by manually activating an optional smoke and heat ventilation push-button. The smoke and heat ventilation push-button fulfils the following tasks:

- 1 **Trigger** the SHEV function
- 2 **Reset** the SHEV group To do this, the push-button at the top right is pressed
- 3 **Close** the SHEV group If the push-button is pressed once, the SHEV group moves autonomously in the close direction.
- 5 **Visual indication** of the operating state:
 - green: Operating
 - red: Triggered
 - yellow: Malfunction

Up to 10 smoke and heat ventilation push-buttons can be combined in a line. To do this, a 33 KOhm terminating resistance must be connected in the last (or only) smoke and heat ventilation push-button in the line.

Characteristic technical data

TYPE	SHEV push-button IP54
LED OPERATING VALUES	24 V +50 %/-30 %/2 mA DC1
BREAKING CAPACITY OF ALL PUSH-BUTTONS	24 V +50 %/-30 %/20 mA DC1 (normally open)
SCREW TERMINALS	max. 1.5 mm ²
ENVIRONMENTAL CLASS	3 (-5 °C to +40 °C)
TEMPERATURE RANGE	Flame-retarded up to 90 °C
BOX	125 mm × 145 mm × 55 mm, orange (RAL 2011), weather protection: grey (RAL 7035)



Weather protection cover

A weather protection cover is also supplied to extend the safety class to IP54.

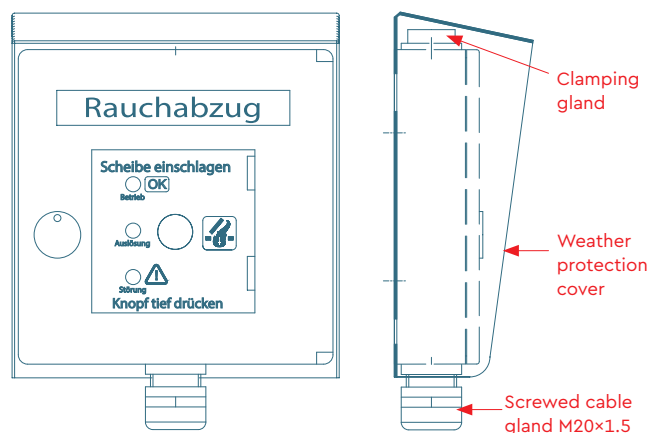



Automatic smoke or heat detector

ECO 1005T/ECO 1003

Optionally, the hatches can be extended with automatic detectors. There are two different types to choose from: the ECO 1005T maximum heat detector or alternatively the ECO 1003 optical smoke detector.

Both detectors have a removable cover to simplify cleaning operations. Internally, they are equipped with an easy-to-clean insect protection system. The detector boxes are encapsulated to prevent penetration by moisture and crawling animals (to prevent false alarms).

The detector is supplied together with a stainless steel bracket that is mounted on the angle bracket frame.

The design can be seen in *selection 9, variant 6, 11 and 12*. There is no need for additional assembly work.

Attention: The detectors are not suitable for use in damp rooms (IP00)!

Technical data

TYPE	ECO 1005T fixed temperature heat detector	ECO 1003 smoke detector
OPERATING VOLTAGE	8-30 V DC	
OPERATING TEMPERATURE	-30 °C to +70 °C	
COLOUR	similar to RAL 9016 ("traffic white")	
AIR HUMIDITY	5 % to 95 %	
TRIGGER TEMPERATURE	58 °C	—
IDLE CURRENT	55 µA (typical)	45 µA (typical)
VdS APPROVAL NUMBER	G 201073	G 201060
SAFETY CLASS	IP00	



Optional
ECO 1005T maximum
heat detector



Optional
Optical ECO 1003
smoke detector

Bracket
made of stainless steel
for mounting on the
angle bracket frame



Installation examples for installation without false ceiling – Natural smoke evacuation

If you plan to use natural smoke extraction in your building project then it is vitally important that the **systems are compatible with one another**. It must be ensured at the installation site that the two systems cannot interfere with one another under any circumstances. The reliability of the smoke evacuation function must be assured at all times. At the geometrical level, the installation space provided must be sufficient to enable the systems to open simultaneously without touching one another at any point.

Alternatively, it is possible to consider using a sequence controller. We are able to design an optimised hatch for these operating conditions by adapting the width of the hatch sheet and the opening angle.

Please note that unobstructed access to the hatch must be possible at all times. There must also be sufficient space to perform assembly and maintenance work.

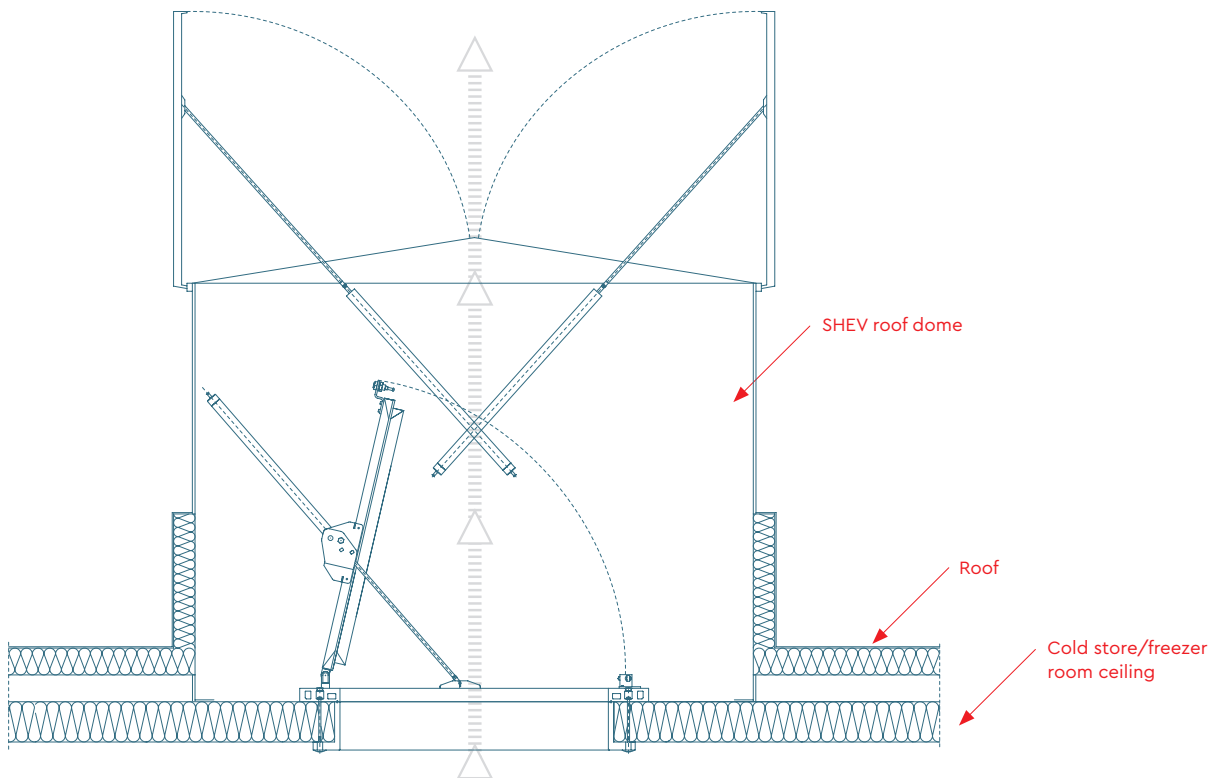

Example installation in a system with natural smoke evacuation

The SHEV hatch and SHEV roof dome systems must be compatible.

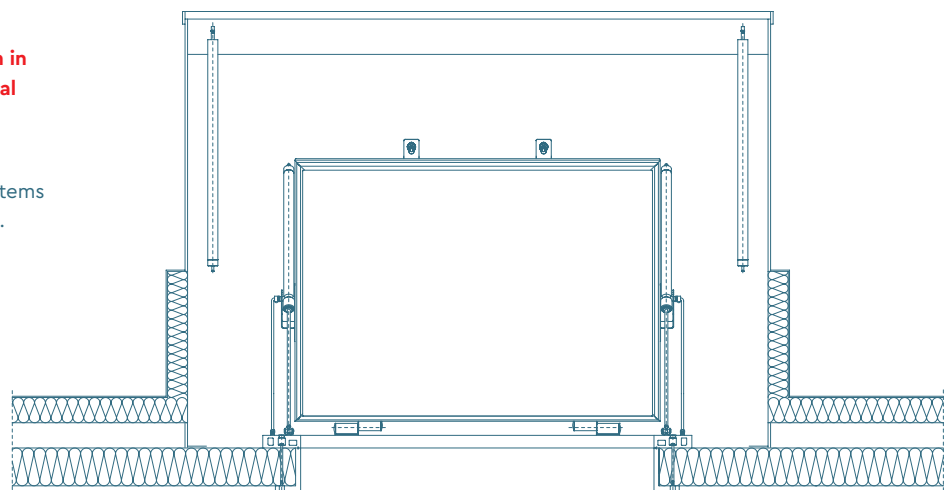

Installation examples for installation without false ceiling – Mechanical smoke evacuation

When *cool it* smoke and heat ventilation hatches are used in a **system with mechanical smoke evacuation**, it is essential to use the feedback contact (see *selection 6*) for the "hatch open" state and to analyse this feedback in the customer's on-site control system. It is necessary to ensure that the smoke gas ventilators do not start up until the inlet and exhaust air flows are assured in the corresponding building section. If this requirement is not complied with then the company *cool it* will not accept any liability for consequential loss or damage at the building resulting from the ensuing under/overpressure.

If your building project involves the use of smoke gas ventilators, please request our information material *risk assessments for mechanical smoke ventilation in combination with smoke and heat ventilation hatches* and read it carefully.

Please note that unobstructed access to the hatch must be possible at all times. There must also be sufficient space to perform assembly and maintenance work.

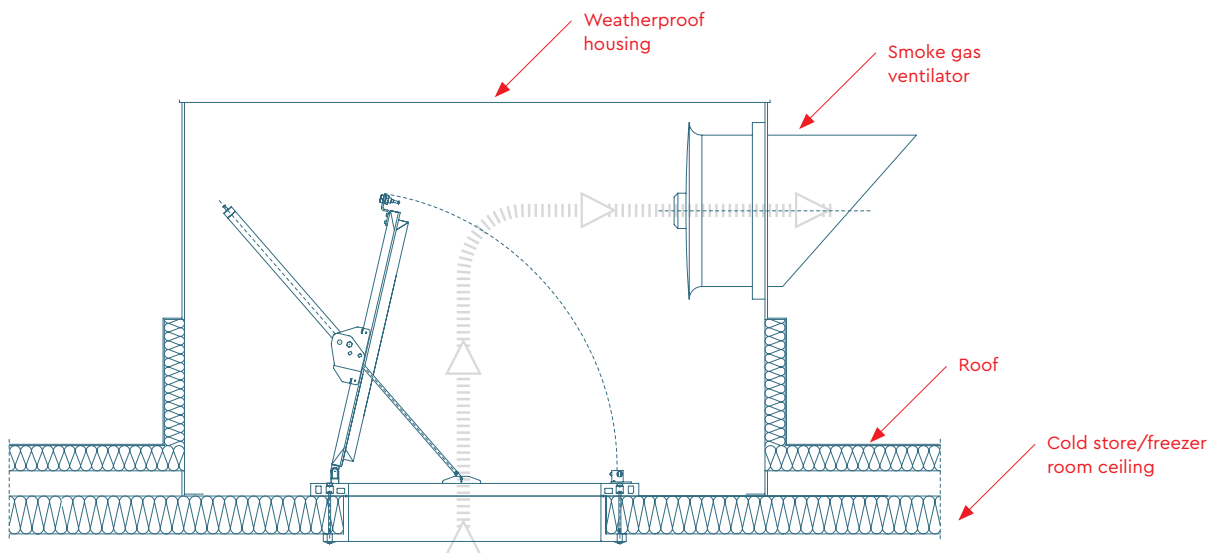

Example installation in a system with mechanical smoke evacuation

It is essential to use a door contact switch/ "hatch open" feedback contact.

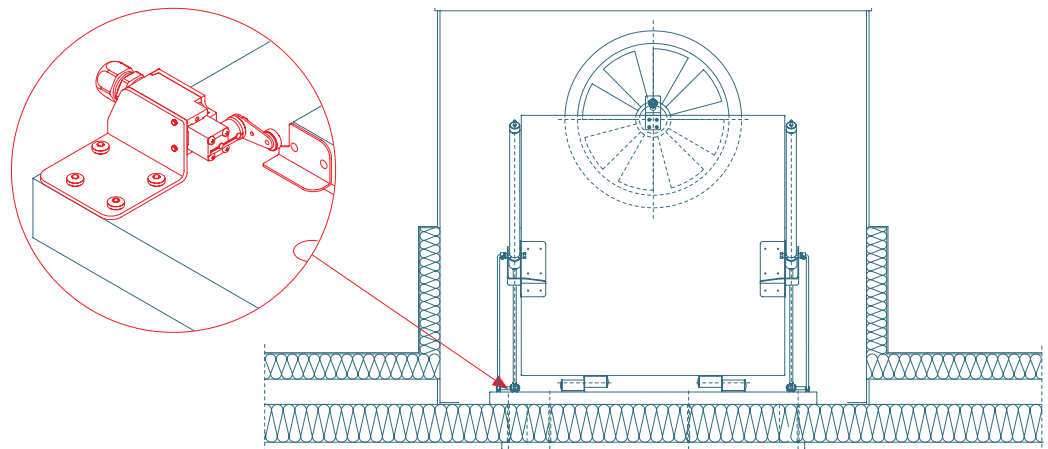

Example of installation in false ceiling with housing for smoke and gas ventilation

When positioning the *cool it* SHEV hatch relative to the smoke evacuation hatches in the roof, it is important to ensure that the rising air is aerodynamically guided as optimally as possible. It is essential to avoid unnecessary eddying. As far as possible, therefore, there should be no cables etc. in the vicinity of the rising smoke gas.

The optimum design variant has an **additional housing** going from the false ceiling to the roof. When planning this housing, it is essential to take account of the free space for the actuating cylinders. In addition, it is necessary to allow sufficient space for installation and maintenance work. The space required for this should be approximately 500 mm on all sides.

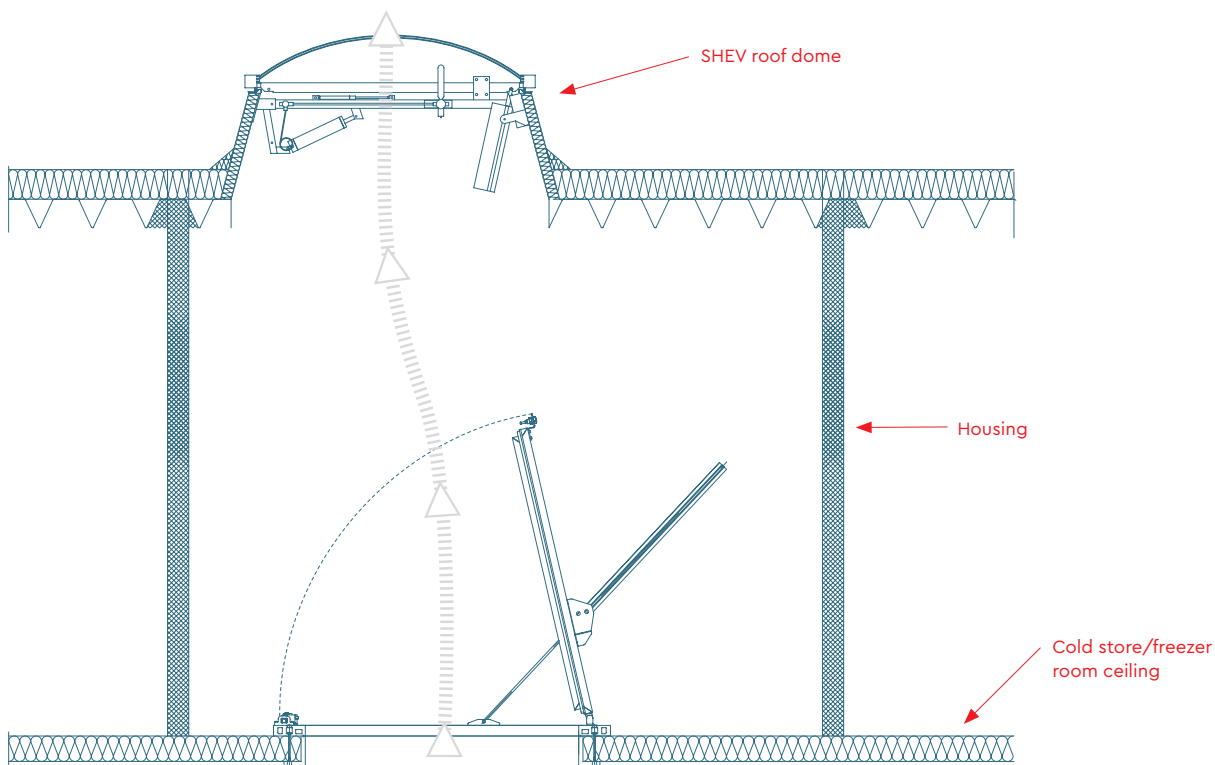

Unhindered, rapid access must be ensured at all times.

If hatches are opened involuntarily in freezer rooms then they must be closed again as quickly as possible. Because pneumatic systems have to be closed manually, it is necessary to ensure rapid access via a hinged door. In such cases, it is advisable to install a *cool it* type D8 hinged door. In freezer rooms, it is advisable to use *cool it* SHEV hatches with electrical actuator which close automatically within 20 seconds at the touch of a button!

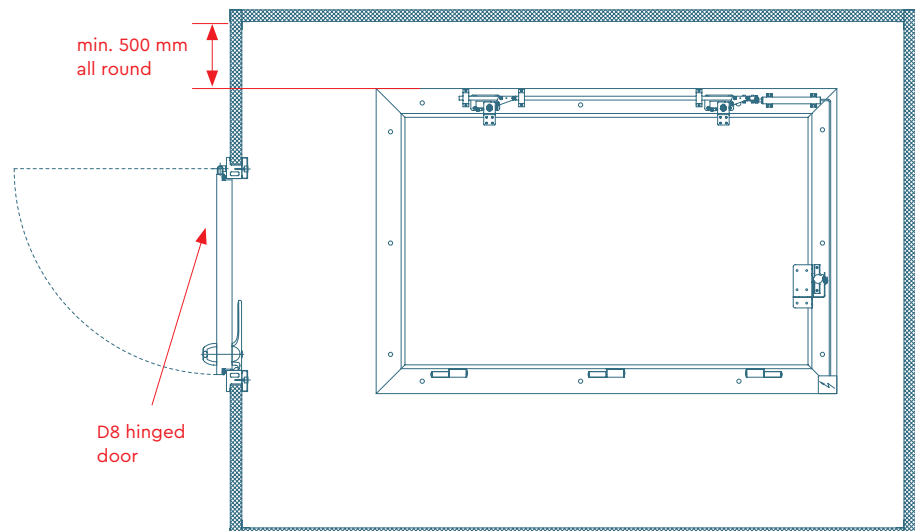

Notes on maintenance and inspection of the SHEV system

Regular, professional maintenance and inspection of the cool it SHEV hatches is essential in order to ensure the permanent correct functioning of the system.

Maintenance is a vital obligation on the part of the owners or operators of the building and is stipulated in various laws, ordinances, guidelines and other regulations. (e.g. § 3 of the German standard building regulations: "Building systems must be arranged, installed and maintained in such a way that [...] in particular, there can be no risk to life and health." § 4 Ordinance on workplaces (ArbStV), Special requirements relating to workplace operation (1): "The employer must maintain the workplace and ensure that any identified deficiencies are eliminated immediately. If deficiencies that are associated with a direct hazard cannot be eliminated immediately then work must be suspended."). If the necessary maintenance work is not carried out then the building owner or operator faces the risk not only of fines and the closure of the works by the authorities but also the loss of any warranty entitlements.

Frequency of maintenance

Servicing and maintenance of the SHEV system must be performed at regular intervals in accordance with DIN 18232 RWA and DIN 57833 (VDE 833) and at least once a year as per the manufacturer's specifications and these activities must be recorded in the inspection log. In addition, a half-yearly visual inspection must be carried out by the operator (DIN 18232-2).

Inspection log

The inspection log must be kept by the operator of the system. It documents the operator's fulfilment of their obligation to maintain the SHEV system in a way that ensures that it is fit for use and operation.

Authorised companies

Maintenance and service work may only be performed by qualified specialist companies in accordance with the above-mentioned DIN standard. Qualified companies are the installer/manufacture of the system or companies trained by or designated as qualified by *cool it*. When replacing wear or spare parts, it is necessary to use original *cool it* spare parts. Only in this way is it possible to ensure that all the system components interact correctly and without error (system compatibility).

Maintenance agreements

cool it offers the corresponding maintenance agreements. During these maintenance operations, only the *cool it* SHEV hatches are inspected and not the entire system.

This maintenance does not replace the inspection of smoke evacuation systems to be performed in accordance with DIN 15232 part 2, DIN 57833 part 1.

The annual inspection is performed automatically by specialist personnel. The agreement on dates and monitoring of the services are naturally undertaken by *cool it*.



Also available:

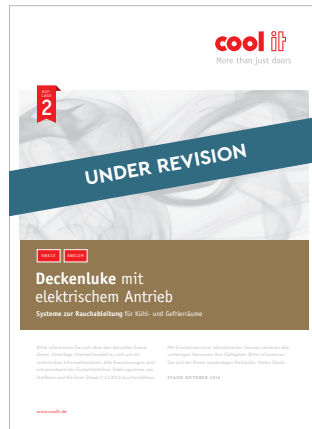

Additional brochures in the pipeline:

BL12ZL Supply air hatch (new for 2021)

BL12RWA Smoke extraction wall hatch to DIN EN 12101:2003 (new for 2021)

Your cool it partner

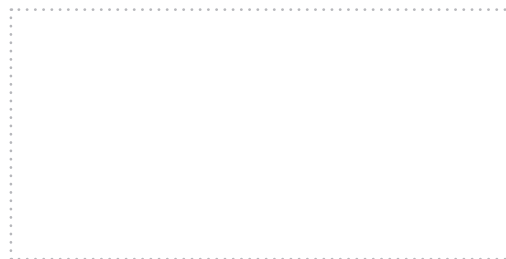

cool it
More than just doors

cool it Isoliersysteme GmbH
Ochsenweg 18 • 49324 Melle

+49 (0) 54 22 6 09 -0
info@coolit.de

www.coolit.de

All indications relating to scope of delivery, appearance, performance characteristics, dimensions, etc. correspond to the information at the time of printing. Some of the doors depicted in this catalogue are equipped with features that are only available at a surcharge. Presented illustrations or details in such illustrations may differ from the original. All information is supplied without guarantee. Subject to technical and other changes, no responsibility accepted for mistakes or printing errors.

© 2021 cool it Isoliersysteme GmbH. All rights reserved.